

Photovoltaic power generation system using a Carrier based PWM inverter

Manisha | Swarnali Saini

Department of Electrical Engineering, Baldev Ram Mirdha Institute of Technology, India

Abstract—Structure electrical converter is one among the foremost recent and fashionable variety of electrical converter founds its applications within the system supported renewable energy. This paper describes a brand new Single-phase seven level electrical converter topology for star electrical phenomenon (PV) system employing a carrier based mostly PWM management theme. This new topology has reduced variety of switches for associate raised variety of levels in comparison to standard seven-level structure electrical converter. Here CPWM shift theme is employed to manage the switches during this structure electrical converter and this electrical converter is fed from a star PV. during this planned topology, six power electronic switches square measure used for a seven-level electrical converter. By victimization this electrical converter topology, the harmonics is reduced and potency is increased considerably. Simulation work is completed victimization the MATLAB/SIMULINK computer code that validates the planned methodology and eventually Total Harmonic Distortion is analyzed.

Keywords— Multilevel Inverter, Photovoltaic (PV) system, Pulse Width-Modulation (PWM), Total Harmonic Distortion (THD).

I. INTRODUCTION

In recent years, solar-energy power-generation systems have raised considerably their capability. these days electrical phenomenon growth is bit by bit raised in Asian nation. structure inverters square measure chiefly used to synthesis a desired single or 3 section voltage wave shape. the required multi-staircase output voltage is obtained by combining many dc voltage sources. star cells, fuel cells, batteries and ultra-capacitors square measure the foremost common freelance sources used. One vital application of structure converters is concentrated on medium- and high-powered conversion. Nowadays, there exist 3 business topologies of structure voltage-source inverters: Neutral purpose Clamped (NPC), Cascaded H-Bridge (CHB), and Flying Capacitors (FCs). Among these electrical converter topologies, cascaded H-bridge electrical converter reaches the elevated output voltage & power levels and therefore the higher responsibility because of its standard topology.

Diode-clamped structure inverters square measure complicates the look and raises responsibility and value concern. they're additionally used in oil mills, metal works places, power generations, mining method and industry. they need been reported to be utilized in a consecutive configuration for regenerative applications. Flying capacitance structure converters are utilized in high-bandwidth high-switching frequency applications [5]. Finally, cascaded H-bridge structure electrical converter has been used for each high power and medium power application. what is more, one among the growing applications of cascade H-bridge structure electrical converter is employed in Uninterruptible Power provides (UPS) and PV [3]. For increasing voltage levels {the variety|the amount|the quantity} of switches additionally can increase in number. thus the voltage stresses and shift losses can increase and therefore the circuit was becomes advanced. By victimization the planned topology variety of switches can scale back considerably and thus the potency can improve. In high power applications, the harmonic

content of the output waveforms must be reduced the maximum amount as doable so as to avoid distortion within the load and to achieve the most energy potency.

The challenge related to techniques is to get the analytical solutions of the non-linear transcendental equations that contain pure mathematics terms that naturally exhibit multiple sets of solutions. usually the lower order harmonics square measure inflicting additional effects in comparison to the upper order harmonics. it's terribly massive challenges for all researchers to eliminate the lower order harmonics victimization PWM techniques [4]-[8].

Traditional 3 level electrical converters square measure investigated with the analysis and cascaded H-bridge seven-level inverter is modelled and analysis is administrated. Finally the planned topology is bestowed with the implementation of PWM. The Doctor of Theology values for the traditional and planned inverters were analysed [4].

II. H-BRIDGE MULTILEVEL INVERTER

The traditional 2 or 3 levels electrical converter doesn't fully eliminate the unwanted harmonics within the output wave shape. Therefore, victimization the structure electrical converter as another to ancient PWM inverters is investigated [2],[7].

In this topology the quantity of section voltage levels at the convertor terminals is $2N+1$, wherever N is that the variety of cells or dc link voltages. during this topology, every cell is separate by individual dc link capacitance and therefore the cells across the capacitance might need totally different voltage drops. so it needs one dc voltage supply for every power circuit. the quantity of dc link capacitors is proportional to the quantity of section voltage levels. every H-bridge cell might need positive, negative or zero voltage. Final output voltage is that the total of all H-bridge cell voltages and is radially symmetrical with relation to neutral

purpose, therefore the variety of voltage levels is odd. Cascaded H-bridge structure inverters generally use IGBT switches [2]. These switches have low block voltage and high shift frequency.

Consider the seven-level inverter: It needs twelve IGBT switches and 3 dc sources. the facility circuit of electrical converter is shown within the Fig.1. A cascaded H-bridges structure electrical converter is solely a series affiliation of multiple H-bridge inverters. each H-bridge electrical converter has a similar configuration as a typical single-phase full-bridge electrical converter

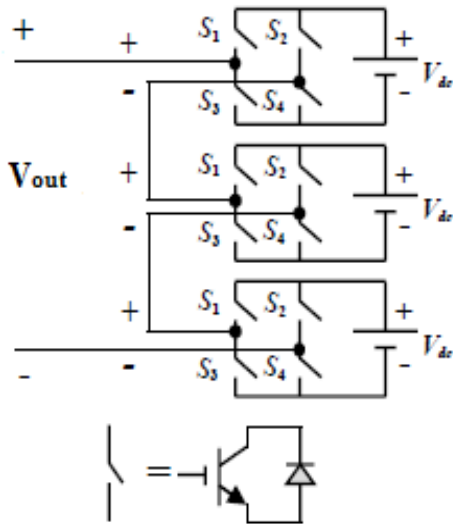

Fig. 1. Conventional cascaded H-bridge

The cascaded H-bridges multilevel inverter introduces the idea of using Separate DC Sources (SDCSs) to produce an AC voltage waveform. All H-bridge inverter is connected to its own DC source V_{dc} [7]. AC voltage waveform is obtained by cascading the each H-bridge inverter.

Each H-bridge inverter can create three different voltages: $+V_{dc}$, 0 and $-V_{dc}$.

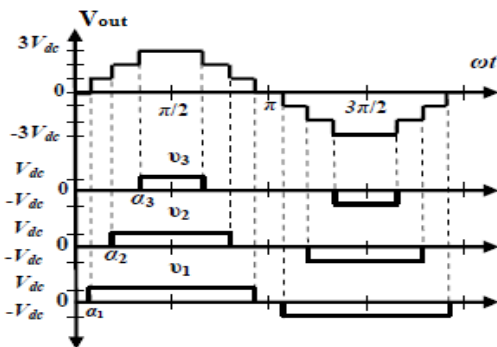

Fig. 2. Output Voltage of cascaded H-bridge seven level inverter

It is also possible to be modularized circuit layout and packaging because each level has the same structure, and does not have extra clamping diodes or voltage matching capacitors. The number of switches is reduced using the modified H-bridge inverter topology.

III. PROPOSED NOVEL TOPOLOGY

The most objective is to provide the standard output voltage of the structure electrical converter with reduced variety of switches. a crucial issue in structure electrical converter style is that the voltage wave shape is close to curving and therefore the lower order harmonics square measure eliminated [3],[8].

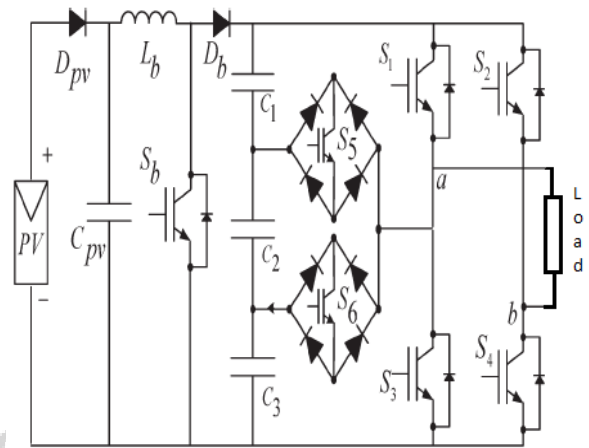

Fig. 3. Proposed Power circuit for 7-level output

A key concern within the elementary shift theme is to work out the shift angles so as to provide the basic voltage while not generating specific lower order harmonics.

There square measure seven modes of shift operation for the 7-level structure electrical converter. These modes square measure shown as in below

TABLE I
SEVEN-LEVEL OUTPUT VOLTAGE ACCORDING TO SWITCHES ON-OFF CONDITION

Output Voltage	S1	S2	S3	S4	S5	S6
V_{dc}	ON	OFF	OFF	ON	OFF	OFF
$2V_{dc}/3$	OFF	OFF	OFF	ON	ON	OFF
$V_{dc}/3$	OFF	OFF	OFF	ON	OFF	ON
0	OFF	OFF	ON	ON	OFF	OFF
$V_{dc}/3$	OFF	ON	OFF	OFF	ON	OFF
$2V_{dc}/3$	OFF	ON	OFF	OFF	OFF	ON
V_{dc}	OFF	ON	ON	OFF	OFF	OFF

The planned topology has the advantage of the reduced variety of power shift devices, however on the outlay of the high rating of the most six switches. Hence, it's counseled for medium power applications.

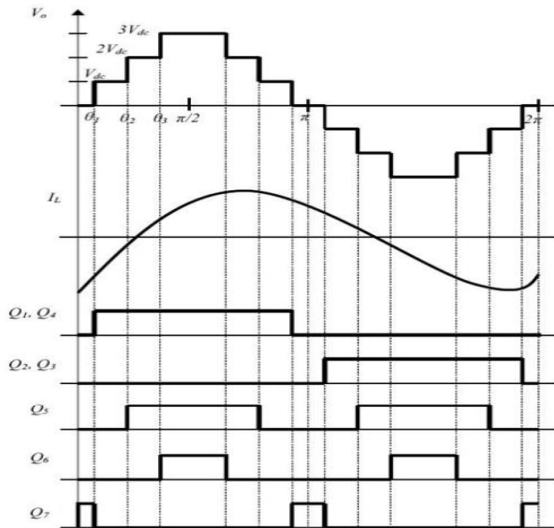

Fig. 4. Waveforms for proposed seven-level inverter

From the Fig. four shift pattern for the assorted switches square measure explained. during this paper harmonic shift theme is used that reduces the shift losses. as a result of shift frequency is a smaller amount during this methodology in comparison to the opposite devices. shift losses square measure directly proportional to the shift frequency..

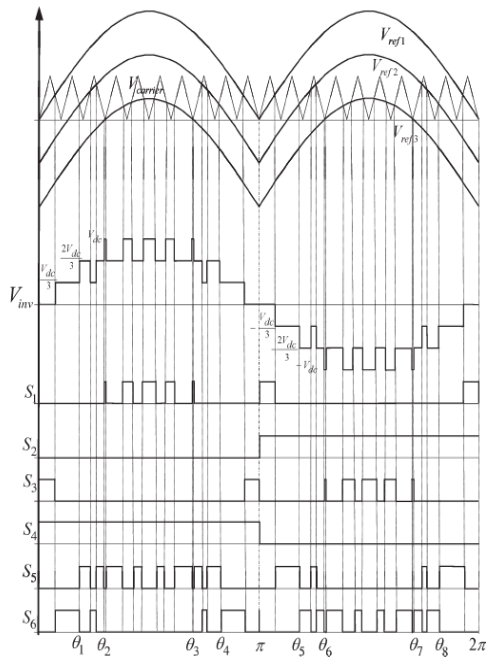

Fig. 5. Switching pattern for single-phase seven-level inverter

IV. PWM MODULATION

shift signals. 3 reference signals (Vref1, Vref2, and Vref3) were compared with a carrier signal (Vcarrier), thus it referred to as Carrier based mostly Pulse dimension Modulation (CPWM). The reference signals had a similar frequency associated amplitude and were in section with an offset price that was cherish the amplitude of the carrier signal. The reference signals were every matched with the carrier signal. If Vref1 had overdone the height amplitude of Vcarrier, Vref2 was compared by Vcarrier till it had exceeded the height amplitude of Vcarrier. Formerly, Vref3 would take hold and would be compared with Vcarrier till it reach zero.

Once Vref3 had reaches zero, Vref2 would be compared till it reached zero. Then, Vref1 would be compared with Vcarrier. Fig. five shows the ensuing shift pattern. Controls S1, S3, S5, and S6 would be shift at the speed of the carrier signal frequency, but S2 and S4 would operate at a frequency that was cherish the basic frequency [6],[1]. For one cycle of the basic frequency, the planned electrical converter runs over six modes. Fig. half dozen shows the per unit output-voltage signal for one cycle.

The six pulses of modes are described as follows:

$$\text{Mode 1 : } 0 < \theta t < \theta_1 \text{ and } \theta_4 < \theta t < \theta$$

$$\text{Mode 2 : } \theta_1 < \theta t < \theta_2 \text{ and } \theta_3 < \theta t < \theta_4$$

$$\text{Mode 3 : } \theta_2 < \theta t < \theta_3$$

$$\text{Mode 4 : } \theta < \theta t < \theta_5 \text{ and } \theta_8 < \theta t < 2\theta$$

$$\text{Mode 5 : } \theta_5 < \theta t < \theta_6 \text{ and } \theta_7 < \theta t < \theta_8$$

$$\text{Mode 6 : } \theta_6 < \theta t < \theta_7 \text{ and } \theta_8 < \theta t < 2\theta \quad (1)$$

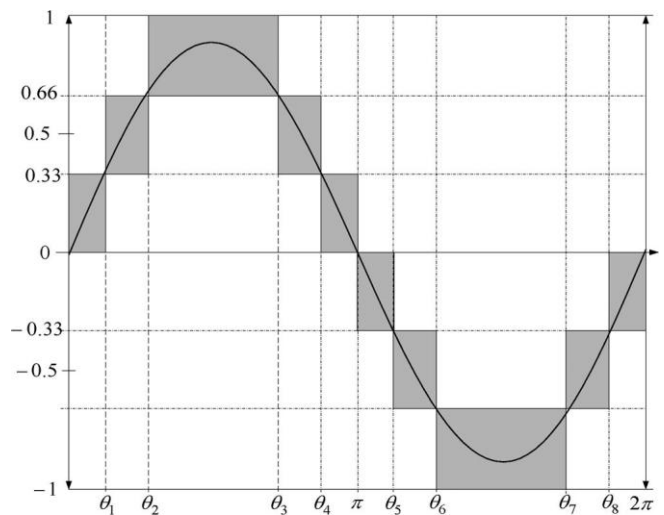

Fig. 6. Seven-level output voltage (Vab) and switching angles.

The phase angle depends on modulation index M_c . Theoretically, for a single reference signal and a single carrier signal, the modulation index is defined as

$$M_e = \frac{A_m}{A_c} \quad (2)$$

While for a single-reference signal and a three carrier signal, the modulation index is defined as

$$M_e = \frac{A_m}{2A_c} \quad (3)$$

Since the proposed seven-level inverter utilizes PWM switching of three carrier signals, the modulation index is well-defined as

$$M_e = \frac{A_m}{3A_c} \quad (4)$$

Where A_c is the peak-to-peak value of the carrier signal and A_m is the peak value of the voltage reference signal V_{ref} . When the modulation index is lesser than 0.33, the phase angle displacement is

$$\theta_1 = \theta_2 = \theta_3 = \theta_4 = \pi/2 \quad (5)$$

$$\theta_5 = \theta_6 = \theta_7 = \theta_8 = 3\pi/2 \quad (6)$$

On the other hand, when the modulation index is higher than 0.33 and lesser than 0.66, the phase angle displacement is determined by

$$\theta_1 = \sin^{-1}(A_c/A_m) \quad (7)$$

$$\theta_2 = \theta_3 = \pi/2 \quad (8)$$

$$\theta_4 = \pi - \theta_1 \quad (9)$$

$$\theta_5 = \pi + \theta_1 \quad (10)$$

$$\theta_6 = \theta_7 = 3\pi/2 \quad (11)$$

$$\theta_8 = 2\pi - \theta_1 \quad (12)$$

If the modulation index is other than 0.66, the phase angle displacement is determined by

$$\theta_1 = \sin^{-1}(A_c/A_m) \quad (13)$$

$$\theta_2 = \sin^{-1}(2A_c/A_m) \quad (14)$$

$$\theta_3 = \pi - \theta_2 \quad (15)$$

$$\theta_4 = \pi - \theta_1 \quad (16)$$

$$\theta_5 = \pi + \theta_1 \quad (17)$$

$$\theta_6 = \pi + \theta_2 \quad (18)$$

$$\theta_7 = 2\pi - \theta_2 \quad (19)$$

$$\theta_8 = 2\pi - \theta_1 \quad (20)$$

For M_e that is equal to, or less than 0.33, simply the lower reference wave (V_{ref3}) is compared with the triangular carrier signal. The inverter's performance is similar to that of a conventional full-bridge three-level PWM inverter. However, if M_e is more than 0.33 and less than 0.66, individual V_{ref2} and V_{ref3} reference signals are compared with the triangular carrier wave. The modulation index is fixed to be more than 0.66 for seven-level of output voltage to be created. Three reference signals have to be matched with the triangular carrier signal to produce switching signals for the switches.

V. SIMULATION

The MATLAB simulation circuit was developed for the conventional seven-level and proposed inverter with PWM implementation.

A. Simulation of Conventional Seven Level Inverter

This circuit consists of 12 IGBT switches with 3 equal dc sources. The gate pulses are generated by using the pulse generator.

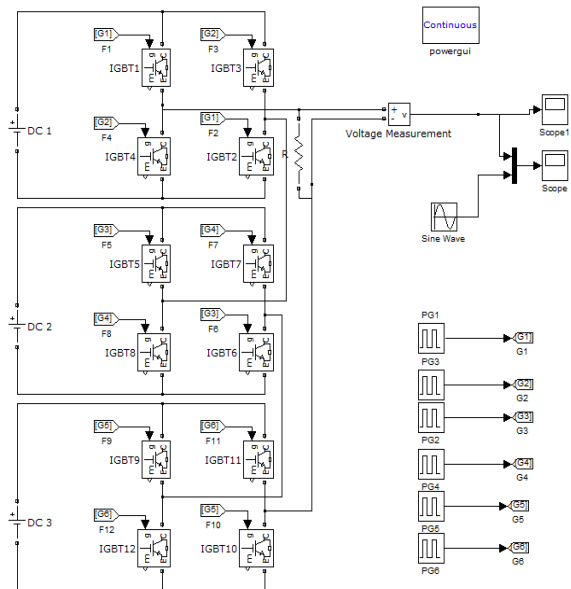

Fig. 7. Simulation Model for conventional seven-level Inverter

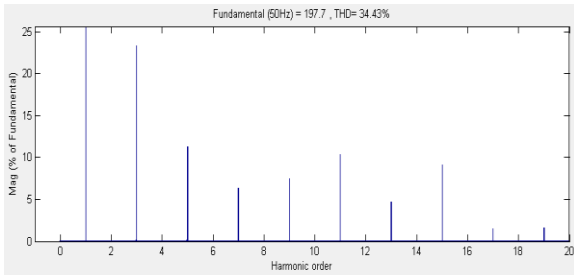

Fig. 8. Harmonic spectrum of Output voltage of seven-level H-bridge inverter

From the harmonic analysis of seven level output voltage of the 12 switch H-bridge inverter, the THD value is obtained as 34.43%.

B. Simulation of the Proposed PV model

The simulation model of a PV cell is shown Fig. 9. It consists of a perfect current supply and temperature supply square measure connected to PV array block. The present sources represent the present generated by photons and its output is constant underneath constant temperature and constant incident radiation of sunshine.

There square measure 2 key parameters temperature and current supply oftentimes wont to characterize a PV cell.

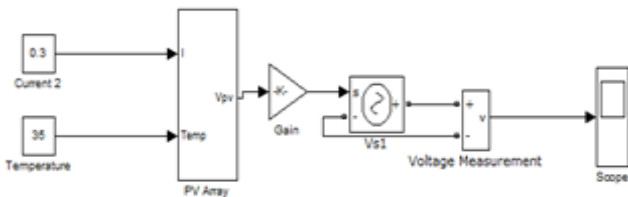

Fig. 9. Simulation for proposed PV model

C. Simulation of the Proposed Boost Converter

The simulation model of a lift converter is shown Fig. 10. Its output voltage is beyond the input voltage. Whenever the IGBT is turned on energy is hold on on the boost electrical device. once the IGBT is turned off the voltage across the electrical device reverses and adds to the input voltage to charge the output capacitance.

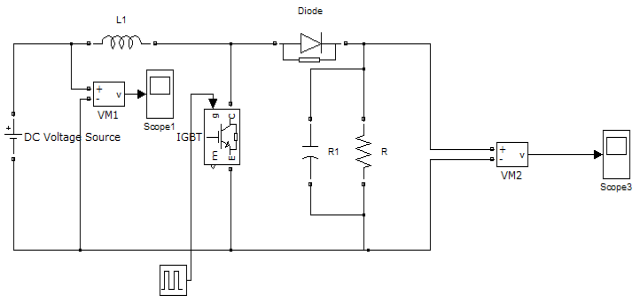

Fig. 10. Simulation Model of Boost Converter

During the time switch is closed, the electrical device current will increase linearly. once the switch is open, the electrical device current decreases linearly and reaches to its minimum level. PV output is connected to the boost converter.

D. Simulation of the Proposed Inverter Topology

The Simulink model diagram for the planned circuit is shown in Fig. 11. It recounts the event of a unique changed H-bridge single-phase structure electrical converter that has 2 diode embedded bifacial switches and a unique Carrier based mostly pulse dimension modulated (CPWM) technique. The topology was applied to an advertisement load connected electrical phenomenon system. it's solely six switches and additionally to cut back Doctor of Theology within the electrical converter output. Its Doctor of Theology price is obtained as twenty two.85%, that is that the best among convention methodology electrical converter. This planned harmonic shows that improvement of quality in electrical converter output voltage.

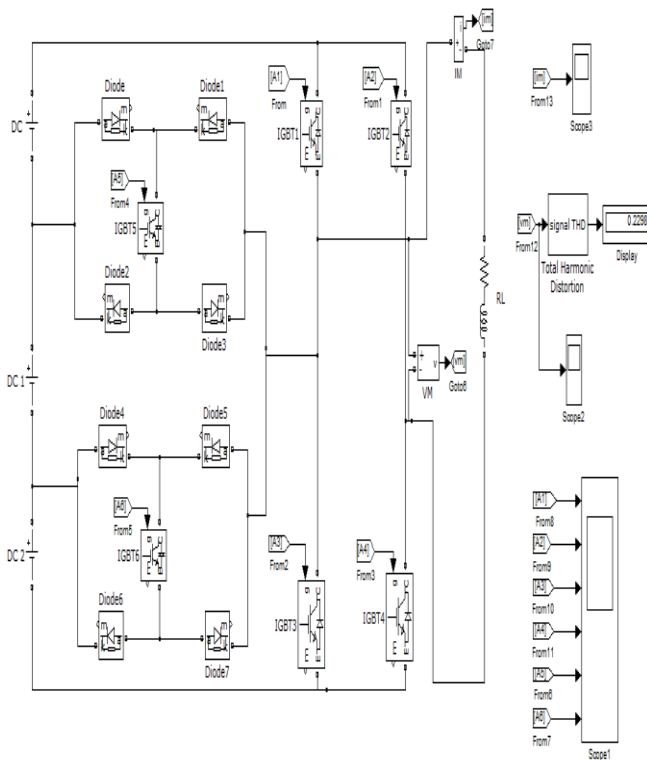

Fig. 11. Simulation model for Proposed Inverter

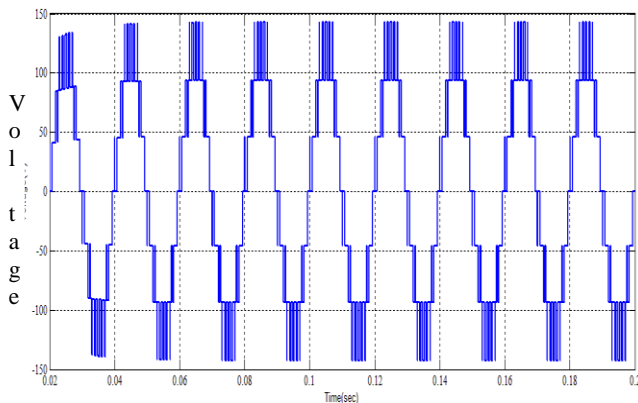

Fig. 12. Seven-level output voltage of proposed Inverter

From the Fig.12 it is clear that seven-level or three stepped waveform is obtained. Then harmonic analysis is carried out with the resistive load.

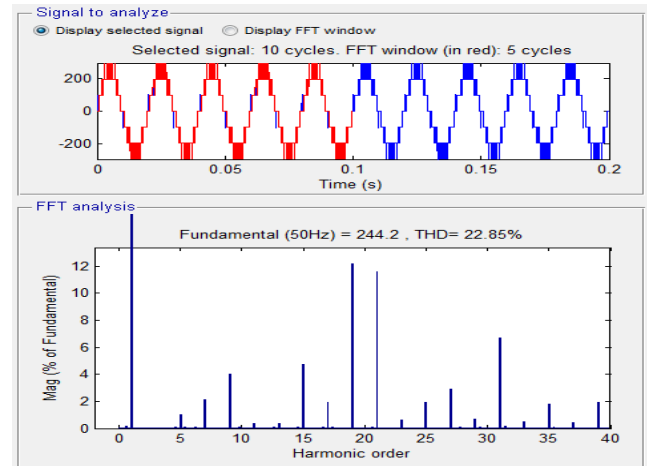

Fig. 13. Harmonic spectrum of output voltage of the proposed inverter

The Simulink model diagram of the planned electrical converter Doctor of Theology analysis is shown in Fig. 13. Its Doctor of Theology price is obtained as twenty two.85%, that is that the best among convention methodology electrical converter. This planned harmonic shows that improvement of quality in electrical converter output voltage.

VI.CONCLUSION

This paper planned a single-phase structure cascaded H-bridge electrical converter for PV Sources. It utilizes 3 reference signals and a carrier signal to come up with CPWM shift. The circuit topology and operational principle of the planned electrical converter were analyzed intimately. Its performance satisfies the demand of versatile and correct wattage generation. because of its modularity, the planned system may be improved by increasing the quantity of levels was reduced its Doctor of Theology. Simulation results indicate that the Doctor of Theology of the seven-level electrical converter is way lesser than that of the traditional seven-level electrical converter. what is more supported these results, it's expected that MLIs for PV systems can become associate effectively enforced for business application shortly.

REFERENCES

- [1] Nandor Bodo, Emil Levi and Martin Jones "Investigation of Carrier-Based PWM Techniques for a Five-Phase Open-End Winding Drive Topology" *IEEE Trans. Ind. Electron.*, vol. 60, no.5, pp.2054-2065, Mar 2013.
- [2] Nasrudin Abd. Rahim, Mohamad Fathi Mohamad Elias and Woo Ping Hew "Transistor-Clamped H-Bridge Based Cascaded Multilevel Inverter With New Method of Capacitor Voltage Balancing" *IEEE Trans. Ind. Electron.*, vol. 60, no. 8, pp. 2934-2956, Aug 2013.
- [3] Abdalla, J. Corda, and L. Zhang "Multilevel DC-Link Inverter and Control Algorithm to Overcome the PV Partial Shading" *IEEE Trans. Power Electron.*, vol. 28, no. 1, pp. 14-18, Jan 2013.

- [4] Dragutin J. Kostic, Zoran Z. Avramovic and Ninoslav T. Ciric "A New Approach to Theoretical Analysis of Harmonic Content of PWM Waveforms of Single- and Multiple-Frequency Modulators" *IEEE Trans. Power Electron.*, vol. 28, no. 10, pp.4557-4567, Oct 2013.
- [5] Ke Ma and Frede Blaabjerg "Modulation Methods for Neutral-Point-Clamped Wind Power Converter Achieving Loss and Thermal Redistribution Under Low-Voltage Ride-Through" *IEEE Trans. Ind. Electron.*, vol. 61, no. 2, pp.835-845, Feb 2014.
- [6] Salvador Alepuz, Sergio Busquets-Monge, Josep Bordonau, Juan A. Martínez-Velasco, César A. Silva, Jorge Pontt and José Rodríguez "Control Strategies Based on Symmetrical Components for Grid-Connected Converters Under Voltage Dips" *IEEE Trans. Ind. Electron.*, vol. 56, no. 6, pp.2162-2173, Jun 2009.
- [7] Elena Villanueva, Pablo Correa, José Rodríguez and Mario Pacas "Control of a Single-Phase Cascaded H-Bridge Multilevel Inverter for Grid-Connected Photovoltaic Systems" *IEEE Trans. Ind. Electron.*, vol. 56, no. 11, pp.4399-4406, Nov 2009.
- [8] Chih-Chiang Hua, Chun-Wei Wu and Chih-Wei Chuang "A Digital Predictive Current Control With Improved Sampled Inductor Current for Cascaded Inverters" *IEEE Trans. Ind. Electron.*, vol. 56, no. 5, pp.1718-1726, May 2009.
- [9] Carlo Cecati, Fabrizio Ciancetta and Pierluigi Siano "A Multilevel Inverter for Photovoltaic Systems With Fuzzy Logic Control" *IEEE Trans. Ind. Electron.*, vol. 57, no. 12, pp.4115-4125, Dec 2010.
- [10] Jeyraj Selvaraj and Nasrudin A. Rahim "Multilevel Inverter For Grid-Connected PV System Employing Digital PI Controller" *IEEE Trans. Ind. Electron.*, vol. 56, no. 1, Jan 2009.