

A PSO BASED MAXIMUM POWER POINT TRACKING ALGORITHM FOR SOLAR PHOTOVOLTAIC PANELS

Muhammad Zeeshan khan | Dr Aamir Qamar | Shoaib Bhutta | Saddam Aziz| kashif Sultan

¹(Electrical Engineering, Chongqing University, China, shankhan392@gmail.com)

²(Electrical Engineering, Chongqing University, China, engr.aamirqamar@yahoo.com)

³(Electrical Engineering, Shenzhen University, China, shoaibbhutta@hotmail.com)

⁴(Electrical Engineering, Chongqing University, China, saddamaziz@yahoo.com)

⁵(Information and Communication Engineering, USTB, China, kashif_rao@outlook.com)

Abstract — With the development of social productivity the social demand for energy is growing and energy crisis is increasing with each passing day. In renewable energy solar energy with ample storage, environmental protection and other features, it has been the most potential development energy. But photovoltaic generations exists major problems, firstly the PV Curve Shows multiple peaks curve in a partial shaded environments, traditional methods of maximum power point easy to fall into local optimum mistakes, tracking result was low in accuracy and slow in convergence, secondly because of independent photovoltaic power generation system in which the environment is very bad so the storage part state influencing factors such as illuminations, temperature they are easy to change and the P-V curve of power generation system exhibits multiple peaks which reduces the effectiveness of conventional maximum power point tracking methods This thesis research on MPPT issues the operational characteristics of PV modules are initially investigated in order to explore the impact of solar irradiation conditions on the current–voltage and power–voltage characteristics of PV modules and derive the corresponding operational requirements of a global MPPT algorithm, which is suitable for applications of PV modules

Key Words: *Partial Shadow Condition (PSC), PSO (particle Swarm optimization, Photovoltaic (PV) Maximum Power point tracking (MPPT).Power generation system (PGS), GMPP Global maximum Power Point Tracking*

I. INTRODUCTION

Energy is absolutely essential for our life. Recently, energy demand has greatly increased all over the world. The research efforts in moving towards renewable energy can solve these problems. Solar energy is one of the most important renewable sources and is widely used However the PV panel has two Main Problems firstly the conversion Efficiency of PV Panel is Very Low Especially under low irradiations Conditions. The efficiency of a PV plant is affected mainly by three factors: the efficiency of the PV panel (in commercial PV panels it is between 8-15% [1]), the efficiency of the inverter (95-98 % [2]) and the efficiency of the maximum power point tracking (MPPT) algorithm (which is over 98% [3]). Secondly the amount of electric power generated by solar PV Panel changes continuously with various

weather Conditions Improving the efficiency of the PV panel is not easy as it depends on the technology available it may require better components, which can increase drastically the cost of the installation Instead, Improving the tracking of the maximum power point (MPP) with new control algorithms is easier, not expensive and can be done even in plants which are already in use by updating their control algorithms, which would lead to an immediate increase in PV power generation and consequently a reduction in its price.

Typically, the commercially available PV modules consist of multiple solar cells connected in series. A bypass diode is connected in parallel to each module (or group of cells within a module) for protection against hot-spot failure For PV arrays formed by flat-plate PV modules, in case that the individual PV modules comprising the PV array receive unequal

amounts of solar irradiation (e.g., due to dust, shading from surrounding buildings, etc.) then the power-voltage characteristic of the PV array exhibits multiple local maxima and only one of them corresponds to the global MPP. In [4], it is shown that local maxima of small amplitude, called “traps”, could also be observed in a measured PV power curve due to circuit non idealities causing measurement errors with amplitude which is a function of the PV voltage. Therefore, partially shaded condition (PSC) is sometimes inevitable because some parts of the module may receive less intensity of sunlight due to clouds or shadows of trees, buildings, and other neighboring objects. PSC can have a significant impact on the power output depending on the system configuration, shading pattern. Some researchers have worked on MPP tracking schemes for (Power Generation System) PGS operating under (Partial Shadow Condition) PSC; a new MPPT technique which is able to operate under PSC is presented. To find the Global MPP, the voltage factors of all the MPPs have to be previously assessed once. Some of them are as follows

Kobayashi et al and Ji et al. [5] propose a two-stage method to track GMPP. First stage of control process is to move the operating point A to the vicinity of real peaks power point using load line. Then the point B is used to send the operating point at point C which is the intersection of I-V curve & load line. After reaching point C controlled mode will be switched to Second Stage in which inverter is being controlled to minimize the difference b/w V/I and $-dV/dI$. Then operating point will converge to point D. Advantage of this method is The GMPPT Control system can track the real power peak under non uniform insolation conditions even when the insolation condition dramatically changes. Disadvantage of this method is it cannot obtain the GMPP lies on left side of the load line.

Patel and Agarwal [6] also propose methods to track the GMPP. The proposed Algorithm work in a junction to track Global point which uses the Reference Voltage information from tracking Algorithm to shift operation towards MPP. Basic principle of this method is: A global Stage is used to find the regions of local MPP Second Step local stage employs P&O is used to find GMPP. Advantage of method is simple yet effective to track GMPP in case of partial shadow Condition and can be implemented by an inexpensive low end micro controller. The scheme is also effective under uniform insolation conditions. Disadvantage is the tracking speed is

limited because almost all local MPP Can be found as compare to obtain GMPP.

Gao Et Al [7] also proposes parallel configuration at individual cell because voltage of every parallel configuration is largely independent. Every cell in PV module has been treated as one single unit that tracks its MPP under Non Ideal Conditions. A set up power converter is imposed between the cell and PV panel main Objective is to maintain constant converter i/p voltage equal to solar array Voltage. Advantage of this method is .A configuration portable power system produced maximum power under rapidly changing partial conditions. Parallel configuration has an advantage different panel in cell may supply different current corresponding to irradiance level falling on them all cells share common voltage that will be controlled to track MPP. Disadvantage is the input voltage of these configurations is very low so it is difficult of designing an appropriate power converter. More over proposed configuration is suitable for low power configuration.

Miyatakel [8] attempted to approach the GMPP using PSO. The proposed Algorithm uses only one pair of sensor to control multiple PV Arrays with one pairs of voltage and current Sensor. Advantage is as proposed scheme is multi-dimensional search based technique is able to find GMPP under complex partial conditions Disadvantage of This method is only suitable for the system that contains multiple converters.

Ishaque et al. [9] present an improved PSO-based MPPT algorithms for PGS, the advantages of using PSO in conjunction with the direct duty cycle control are discussed in detail. However, no system design guidelines and practical design considerations are provided.

This paper aims to develop the maximum power point particle swarm optimization algorithm that can operate under partial shadow condition. The standard version of Particle swarm optimization is modified that can operate under Partial shadow condition A 298 W prototype will be implemented to demonstrate the validity of Proposed MPPT algorithm. According to the simulation the proposed method can reach the Maximum power point in less iteration.

II. MODELING OF THE PHOTOVOLTAIC SYSTEM

A. Basic Characteristic of a PV Cell

A PV cell can A PV cell can be represented by an electrical equivalent one diode model as shown in

Fig. 1. This model contains a current source I_g , a diode D, and a series resistance R_s , which represents the resistance inside each cell and in the connection between the cells. The net current I_{pv} is the difference between the photocurrent I_g and the diode current I_D :

$$I_{pv} = I_g - I_s \left(\exp\left(\frac{q(V_{pv} + I_{pv} \cdot R_s)}{\eta k T}\right) - 1 \right) \quad (1)$$

Where η is the diode ideality factor, k is Boltzmann's constant q is the electron charge, T is the temperature in kelvin, R_s is the equivalent series resistance and I_s is the saturation current respectively.

III. DESIGNING OF DC/DC BOOST CONVERTER FOR PV

A. DC-DC Boost Converter for Photo Voltaic System

Photovoltaic (PV) power-generation systems are becoming increasingly important and prevalent in distribution generation systems. Unfortunately, the power capacity range of a single PV module is usually about 100 W to 300 W, and the maximum power point (MPP) voltage range is from 15 V to 40 V. These values are low when comparing with the required input voltage of inverters; making it difficult to reach high efficiency. In this case, the difference between the low voltage of PV modules and the required input voltage of inverters can be compensated by the connection of various PV modules in series. However, the generated output power of the PV arrays is decreased greatly due to module mismatch or partial shading, resulting in difficulties to reach the MPP for every PV panel or for whole and then reducing system efficiency

Thus, the modular power conversion without galvanic isolation may be promising because it is less perturbed and it would allow an effective use of the energy available in the PV arrays, but its output voltage is low. Therefore, in this context, it is necessary to utilize a step-up DC-DC converter as intermediate stage between the PV arrays

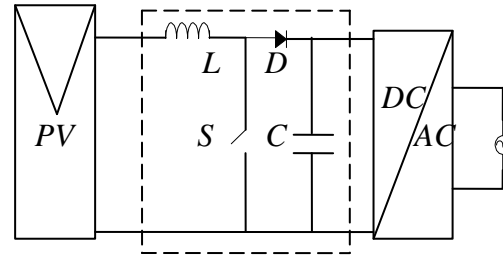

-----DC/DC Boost Converter
Fig: 1.1 Boost Converters for PV

Fig 1.1 shows a grid connected PV application system using dual power processing system. The dotted line shows the DC/DC Boost Converter from the block diagram. The boost converter shown in above figure dotted lines is a medium of power transmission to perform energy absorption and injection from solar panel to grid-tied inverter. The process of energy absorption and injection in boost converter is performed by a combination of four components which are inductor, electronic switch, and diode and output capacitor.

B. DC/DC Boost Converter with PV Module Simulation

To verify the correctness a 298.5 W prototyping circuit is implemented from which simulations and experiments are carried out accordingly. Boost Converter topology is developed in Matlab Simulink the block diagram of the MATLAB-Simulink-based PV module, where the proposed model and the flow in sector B are implemented by an S-Function builder with seven inputs and one output. S_1 is irradiance, T is the temperature of the PV module, V is the output voltage of the PV module, and I_{out} is the output current of the PV module. I_{out} Connecting to a controlled current source is used for simulating the output current of the PV module. A bypass diode is connected in parallel with the controlled current source. The parameters of the utilized PV module are listed in Table 1.

TABLE 1.1 Parameters of DC/DC Boost Converter

Maximum Power	298.5 W
Open Circuit Voltage	63.2 V
Maximum Voltage	50.6 V
Maximum Current	5.9 A
Temperature	25 °C
Solar irradiance	1000 W/m ²
Capacitor 1	200 μF
Capacitor 2	600 μF
Inductor	1 mH

Fig 1.2 shows the interfacing of PV Module with DC/DC Boost Converter output power also shows the desired characteristic as the power level increases with the increased level of irradiation .The amount of power generated by the PV is highly depends on the operating point of the PV array where the maximum power point (MPP) varies with solar insolation and temperature.

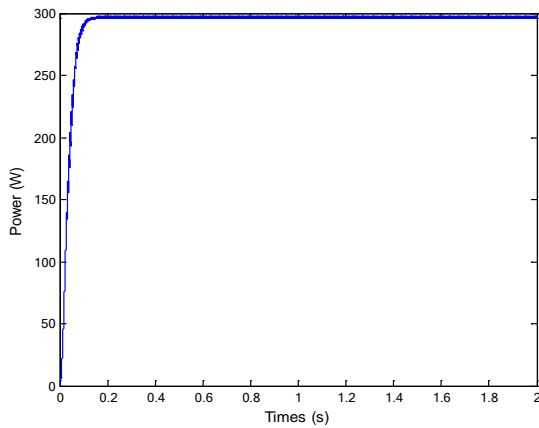

Fig 1.2: Typical simulation of the Power of the Boost converter.

IV. PSO BASED MPPT

A. General Overview of PSO Algorithm

PSO is a swarm intelligence optimization algorithm developed by Eberhart and Kennedy in 1995, which is inspired by the social behavior of bird flocking and fish schooling. It is a stochastic, population-based search method, modeled after the behavior of bird flocks [10]. PSO is a global

optimization algorithm for dealing with problems on which a point or surface in an n-dimensional space represents a best solution. In this algorithm, several cooperative agents are used, and each agent exchanges information obtained in its respective search process. Each agent, referred to as a particle, follows two very simple rules, i.e., to follow the best performing particle, and to move toward the best conditions found by the particle itself. By this way, each particle ultimately evolves to an optimal or close to optimal solution. The position of a particle is, therefore, influenced by the best particle in a neighborhood $p_{best,i}$ as well as the best solution found by all the particles in the entire population g_{best} .

Figure 1.3 Block Diagram Movement Of Particles In Swarm Optimization Process. The standard PSO method can be defined using the following equations [11]:

$$v_i(k+1) = wv_i(k) + c_1r_1.(p_{best,i} - x_i(k)) + c_2r_2.(g_{best} - x_i(k)) \tag{02}$$

$$x_i(k+1) = x_i(k) + v_i(k+1) \tag{03}$$

$$i = 1, 2, \dots, N \tag{04}$$

Where x_i is the position of particle i ; v_i is the velocity of particle i ; N shows the number of cycles after each duty cycles it gives the output number of cycles and samples the output power load .The average fitness value of each number of cycles is 100 in proposed Algorithm. K denotes the iteration number; w is the inertia weight; r_1 and r_2 are random variables uniformly distributed within [0, 1]; c_1 and c_2 are the cognitive and social coefficient, respectively. The variable $p_{best,i}$ is used to store the best position that the i th particle has found so far, and g_{best} is used to store the best position of all the particles. The Flow Chart of basic PSO [11] illustrated in fig 1.4 the operating principle of PSO can be described as follows:

➤ **PSO Initialization:** Particles are usually initialized randomly following a uniform distribution over the search space, or are initialized on grid nodes that cover the search space with equidistant points. Initial velocities are taken randomly

➤ **Fitness Evaluation:** Evaluate the fitness value of each particle. Fitness evaluation is

conducted by supplying the candidate solution to the objective function. The Fitness Function To Obtain Maximum Power Point Can be Written as

$$\frac{1}{2} \pi \delta^2 e^{-\left(\frac{x^2+y^2}{2\delta^2}\right)} \quad (05)$$

Where sigma value increases the selection of global best particle and increases the chances of Convergences

➤ **Update Individual and Global Best Data:** Individual and global best fitness values ($p_{best,i}$ and g_{best}) and positions are updated by comparing the newly calculated fitness values against the previous ones, and replacing them $p_{best,i}$ and g_{best} as well as their corresponding positions as necessary.

➤ **Update Velocity and Position of Each Particle:** The velocity and position of each particle in the swarm are updated using equation (02) and (03).

➤ **Convergence Determination:** Check the convergence criterion. If the convergence criterion is met, the process can be terminated; otherwise, the iteration number will increase by 1 and go to step 2.

Fig 1.5 shows the Matlab Simulation diagram of Conventional PSO Algorithm in 2D in which The green point shows Global best Particles tracked by PSO Algorithm

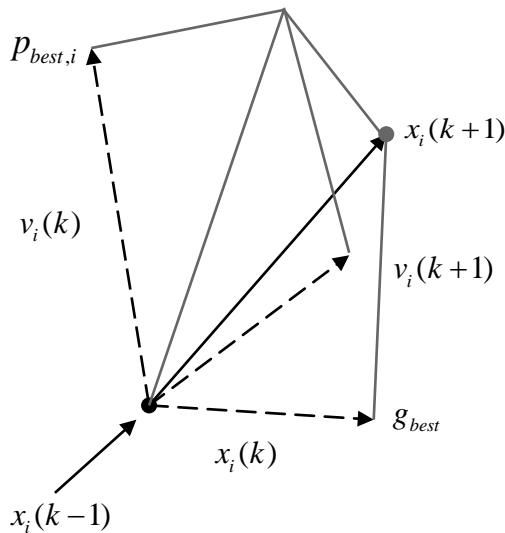

Figure 1.3 Block Diagram Movement Of Particles In Swarm Optimization Process.

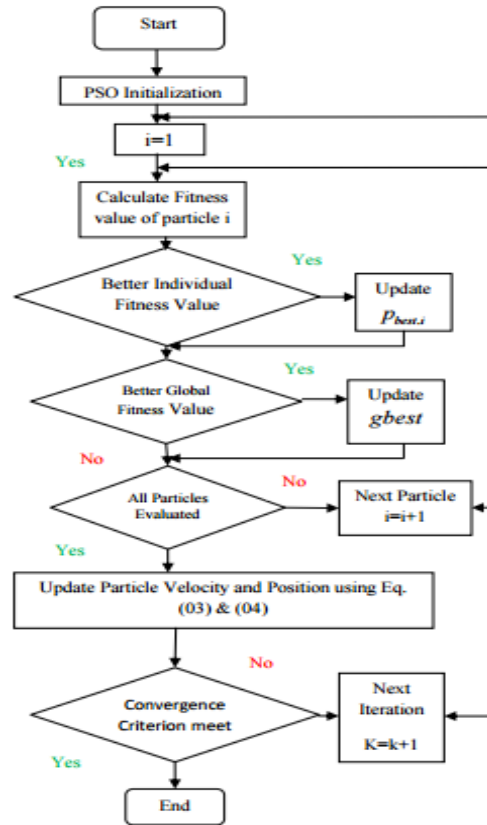

Fig.1.4 Flow Chart of a standard PSO [11]

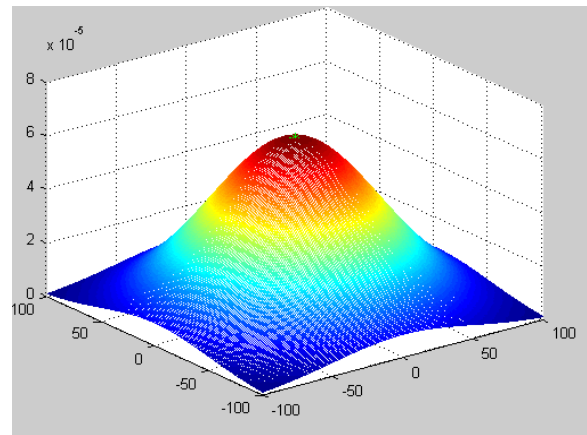

Fig 1.5: Mat lab Simulation diagram of Particle Swarm optimization technique

V. APPLICATION PSO TO MPPT

The PSO method described in Section IV is now applied to realize the MPPT algorithm for PGS operating under PSC. Due to the uniqueness of this problem, the standard version of PSO will be modified to meet the practical consideration of PGS under PSC. Fig 1.6 shows the block diagram of the system consisting of PV Module dc-dc converter and MPPT controller in which Algorithm is implemented. Boost converter is used to step up the operating voltage at the maximum power point. DC-DC boost converter is connected between the solar panel and load.

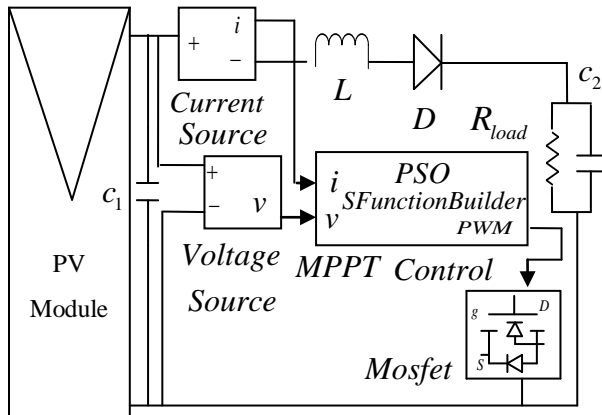

Fig 1.6: Block Diagram of Proposed Method

Fig 1.7 shows the flow chart of Proposed PSO method. The operating principles of a Standard PSO method can be described as follows:

a. Parameter Selection

In the proposed system, the particle position is defined as the duty cycle value d of the dc-dc converter, and the fitness value evaluation function is chosen as the generated power P_{PV} of the whole PGS. From the algorithm point of view, a larger number of particles result in more accurate MPP tracking even under complicated shading patterns. However, a larger number of particles also lead to longer computation time. Therefore, a tradeoff should be made to ensure good tracking speed and accuracy. According to the literature, there exist at most m MPPs in the P-V curve for PV modules consist series connected PV cells [12]. Consequently, the particle number N is chosen as the number of the series connected cells in the PGS.

b. PSO Initialization

In PSO initialization phase, particles can be placed on fixed position or be placed in the space randomly. Basically, if there is information available regarding the location of the GMPP in the search space, it makes more sense to initialize the particles around it. According to [54], the peaks on the P-V curve occur nearly at multiples of 80% of the module open voltage V_{OC} module, and the minimum displacement between successive peaks is also nearly 80% of V_{OC} module. Therefore, the particles are initialized on fixed positions which cover the search space $[D_{min}, D_{max}]$ with equal distances in this paper. D_{min} And D_{max} are the maximum and minimum duty cycles of the utilized dc-dc converter, respectively.

c. Fitness Evaluation

The goal of the proposed MPPT algorithm is to maximize the generated power, P_{PV} the PWM command according to the position of particle i (which represents the duty cycle command), the PV voltage V_{pv} and current I_{pv} can be measured and filtered using digital finite impulse response filters. These values can then be utilized to calculate the fitness value P_{PV} of particle i . It should be noted that in order to acquire correct samples, the time interval between successive particle evaluations has to be greater than the power converter's settling time. The fitness function $f(V, I)$ depends on (V, I) and obtain its maximum at MPPs (V_{mpp}, I_{mpp}) can be written as

$$f(V_{pv}, I_{pv}) = V_{pv} I_{sc} - V_{pv} I_o \left(e^{\frac{q(V_{pv} + I_{pv} R_s)}{\eta K T}} - 1 \right) \quad (06)$$

Where V_{pv} is the voltage, I_{pv} is the current of PV module. I_{sc} is the short circuit current I_o is the reverse saturation current of the diode, q is the electron charge; k is the Boltz Mann's constant T is the temperature η is the ideality factor of diode R_s is the shunt resistance.

d. Update Individual and Global Best Data

If the fitness value of particle i is better than the best fitness value in history, $P_{best,i}$ set current value as the new. Then, choose the particle with the best

fitness value of all the particles as the g_{best} . This step is similar to step 3 of the standard PSO method.

e. Update Velocity and Position of Each Particle

After all the particles are evaluated, the velocity and position of each particle in the swarm should be updated. The update is performed using equation (03) and (04), in which the parameters w , c_1 and c_2 are constants.

f. Convergence Determination

Two convergence criteria are utilized. If the velocities of all particles become smaller than a threshold, or if the maximum number of iterations is reached, the proposed MPPT algorithm will stop and output obtained g_{best} solution.

g. Re initialization:

Typically PSO method is used to solve problems that the optimal solution is time invariant. However, in this application, the fitness value (global maximum available power) often changes with environments as well as loading conditions. In such cases, the particles must be reinitialized to search for the new GMPP again.

$$\frac{|P_{PV,new} - P_{PV,last}|}{P_{PV,last}} \geq \Delta P \quad (07)$$

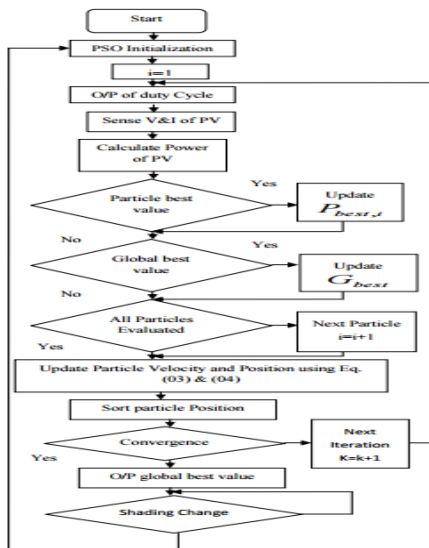

Fig 1.7 flow Chart of Proposed PSO Algorithm VI. SIMULATION RESULTS

To verify the correctness of the proposed MPPT method, a prototyping circuit is implemented from which simulations are carried out accordingly. Simulations are performed using Mat lab/Simulink Software in S function Builder for determining MPP of the solar PV panel

Table 1.2: The parameters setting of the implemented PSO Based MPP Algorithm.

Number Of Particles	20
Generation	100
W_{max}	0.9
W_{min}	0.4
c1	2
c2	2

In table 1.2 the n shows the number of particles initialized in particle swarm optimization technique, generation shows the maximum number of iteration, w was defined as a inertia weight inertia weight must be smaller can make the particles to make careful optimization in the local area of the current, so the algorithm development capacity will be stronger The convergence time of growth, appear extremely easily trapped into local optimal phenomenon. Whereas If The inertia weight is set larger, avoid the local minima, facilitate global search algorithm, can Enhance the ability of exploration, but it is not easy to get the accurate solution, so in W ranges from 0.9 to 0.4 according to the algebraic linear iterative reduced method c_1 is Individual cognitive factor, while c_2 Social learning factor, the algorithm directly gives the definite value it can also be optimized.

In simulation, cell temperature is assumed to be constant at $25^{\circ}C$ unshaded cells are considered fully illuminated at $1000 W / m^2$. Insolation on shaded

cells is considered uniform and varies from 0 to 2000 W / m^2 with a step of $100 W / m^2$.

Fig. 1.8 shows simulated and measured results of a PV array in the process of GMPP in this case. At $t=3s$ In the beginning part of the process, the GMPP strategy scans the output power of a PV array in the range of output voltage from to as it is initially operated at peak Power (297.85 W). If the light changes the proposed method has capability to restart the searching, correct duty cycles are recalculated. Thus a rough global maximum power point (GMPP) could be found. Then, the PSO method continues until the V_{max} is being achieved and finally the maximum load power of PV array (371.7) has been achieved. The output voltage is variable if input power varies it changes to stable.

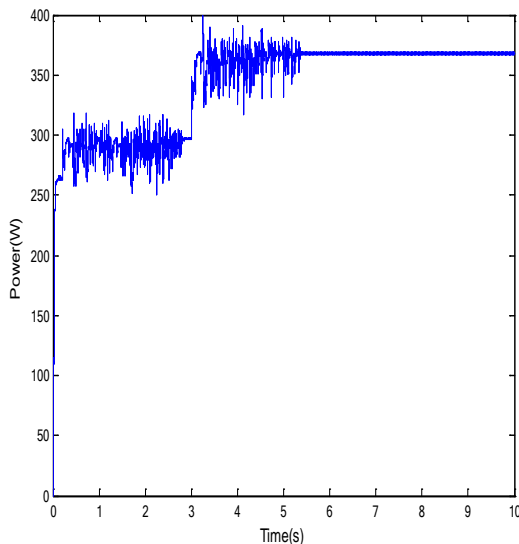

Fig 1.8: Tracking performance of output power

Figure 1.9 shows the tracking performance of power versus voltage the proposed method initially track the local voltage at 198.4 V the resulting local maximum power will become approximately 297.6 W (Then the DC/DC boost circuit boost the voltage up to 218.31 V approximately as shown in graph and A. The resulting Global Maximum power will become approximately 371.1 W.

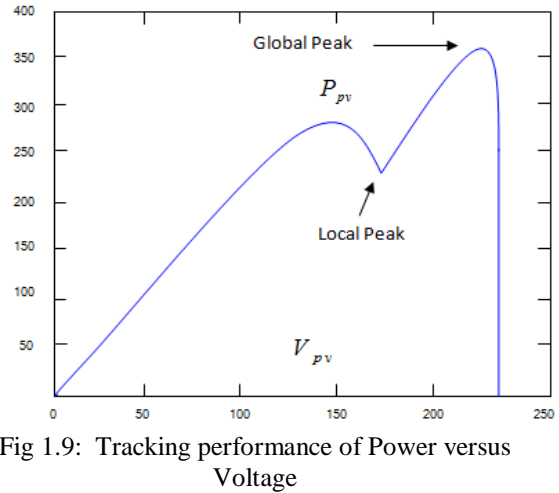

Fig 1.9: Tracking performance of Power versus Voltage

VII CONCLUSION

A MATLAB-Simulink based PV module model is presented in this Paper, which includes a controlled current source and an S-Function builder. To find the maximum power point an accurate and system-independent particle swarm optimization algorithm operating under partial shadow condition is developed. This Algorithm has ability to locate the MPP for any environmental variations including partial shading condition. According to the simulation the proposed method can reach the Maximum power point in less iteration.

REFERENCES

- [1] "Trends in photovoltaic applications. Survey report of selected IEA countries between 1992 and 2009", International Energy Agency, Report IEA-PVPS Task 1T1-19:2010, <http://www.iaea.org/download/Trends-in-Photovoltaic2010>.
- [2] "Sunny Family 2010/2011 - The Future of Solar Technology", SMA product catalogue, 2010, <http://download.sma.de/smaprosta/dateien/2485/SO-LARKATKUS103936W>.
- [3] L. Piegari, R. Rizzo, "Adaptive perturb and observe algorithm for photovoltaic maximum Power point tracking," Renewable Power Generation, IET, vol. 4, no. 4, pp. 317-328, July 2010.
- [4] D. C. Jones and R. W. Erickson, "Probabilistic analysis of a generalized perturb and observe algorithm featuring robust operation in the presence of power curve traps," IEEE Trans. Power Electron., vol. 28, no. 6, pp. 2912–2926, Jun. 2013.
- [5] K. Kobayashi, I. Takano, and Y. Sawada, "A study of a two stage maximum power point tracking control of a photovoltaic system under partially shaded insolation conditions," Sol. Energy Mater. Sol. Cells, vol. 90, no. 18–19, pp. 2975–2988, Nov. 2006.

- [6] H. Patel and V. Agarwal, "Maximum power point tracking scheme for PV systems operating under partially shaded conditions," *IEEE Trans. Ind. Electron.*, vol. 55, no. 4, pp. 1689–1698, Apr. 2008.
- [7] L. Gao, R. A. Dougal, S. Liu, and A. P. Iotova, "Parallel-connected solar PV system to address partial and rapidly fluctuating shadow conditions," *IEEE Trans. Ind. Electron.*, vol. 56, no. 5, pp. 1548–1556, May 2009.
- [8] M. Miyatake, M. Veerachary, F. Toriumi, N. Fujii, and H. KO, "Maximum power point tracking of multiple photovoltaic arrays: A PSO approach.
- [9] K. Ishaque, Z. Salam, M. Amjad, and S. Mekhilef, "An improved particle swarm optimization (PSO)-based MPPT for PV with reduced steady-state oscillation," *IEEE Trans. Power Electron.*, vol. 27, no. 8, pp. 3627–3638, Aug. 2012
- [10] R. Eberhart and J. Kennedy, "A new optimizer using particle swarm theory," in *Proc. 6th Int. Symp. Micro Mach. Human Sci.*, 1995, pp. 39–43.
- [11] K. E. Parsopoulos and M. N. Vrahatis, *Particle Swarm Optimization and Intelligence: Advances and Applications*. Hershey, PA: IGI Global, 2010.
- [12] H. Patel and V. Agarwal, "MATLAB-based modeling to study the effects of partial shading on PV array characteristics," *IEEE Trans. Energy Converters.*, vol. 23, no. 1, pp. 302–310, Mar. 2008