

DESIGN & DEVELOPMENT OF AUTOMATIC SORTING MACHINE FOR COOKED & DRIED TURMERIC RHIZOMES

Arjun Arun Kadam¹ | N.K.Chhapkhane²

¹(M.Tech Scholar, Rajarambapu Institute Technology, Sangli, Maharashtra, India., arjunkadamforu@gmail.com)

²(Dept of Mechanical, Professor, Rajarambapu Institute Tech., Maharashtra, India. narendra.chhapkhane@ritindia.edu)

Abstract—India is a leading nation in a turmeric production. Size is the most important feature for accurate sorting of a turmeric rhizome. Because of the growing need to supply a high quality turmeric rhizomes with in short time, automatic sorting machine of a turmeric rhizomes is the priority of many Indian farmers. The Indian farmers used to a turmeric rhizomes sorting in conventional processes and this processes is time consuming. In this paper the different concepts to develop in a turmeric rhizomes sorting. The selecting the one out of these concept and develop the prototype and do a successful testing a turmeric rhizomes sorting process using image processing as per required parameters. The frame on which sorting machine is mounted is very rigid and can withstand machine weight. Radial & axial forces acting on a conveyor assembly are negligible and therefore life of various mountings such as ball bearings, pulleys, idlers etc. is very long. This makes machine more durable. The sorting efficiency increases if we comparing a conventional process and the new process by up to 70 %. The final design is a compact also a less cost machine which can be also used to another dry fruits sorting. The aim of project comes under the important parameter i.e. automatic turmeric sorting machine for cooked and dried turmeric rhizomes. The main object of a dissertation is to develop a sorting machine by using image processing and give the maximum efficiency of a turmeric rhizome sorting.

Keywords— Development;Sorting;Machine;Turmeric rhizomes

1. INTRODUCTION

India is the largest producer, consumer and exporter of turmeric in the world. Indian farmers even today use the same traditional methods used for turmeric sorting in agricultural works. 8 to 10 workers are required to sort approximately 200 kg Turmeric rhizome per day. The sorting is the most important feature for accurate classification, Because of the ever growing need to supply a high quality food within short period of time. Many required automated grading system. In this context, the field of automation and machine vision comes to play the important role in agriculture. The process of sorting of the turmeric is time consuming and labor intensive process. To overcome the issue of non-availability of laborers and for timely sorting of turmeric, there is a need for automatic sorting machine with higher output.

2. OBJECTIVES:

- To use of latest technologies in agricultural sector.
- To reduce human efforts and time.
- To provide farmers with low cost and highly efficient sorting machine.
- To keep the design portable and simple.
- Should not require any complex manufacturing process.
- So as to minimize the total fabrication cost.

3. STEPS IN PRODUCT DESIGN AND DEVELOPMENT

Concept Development, Identify Customer Needs, Establish Target Specifications, Concepts Generation, Concept selection, Setting final Specifications, Economic Analysis, Plan for Remaining Development Project, System Level

Design, Detail Design, Testing and Refinement, Production Ramp-up

3.1 Identifying Customer Needs

- The sorting of turmeric rhizomes faster than by conventional processes.
- The sorting machine drives on tractors attachment.
- The sorting machine not only works on turmeric rhizomes but also work on another product.
- The sorting machine is comfortable to use.
- The sorting machine Easy to operate
- The sorting machine works on each situation.
- The sorting rate is high.

3.2 Design Challenges

- Irregular shape of turmeric rhizome
- Getting single rhizome at a given rate is difficult due to variation in size
- The dimensions of the electronic component were not known so reserving a proper space for them was a challenge
- Ample light is required for the image processing which was not satisfactory for many of the design concepts. Vibration providing mechanism was a heavy assembly hence its placement was a tedious task

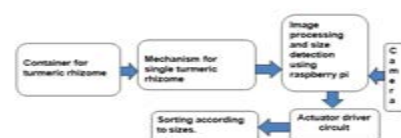

Figure 1: Proposed Work Layout

4. DESIGN EXPLORATION AND PROTOTYPING

4.1 Trapezoidal Hopper Conveyor Mechanism

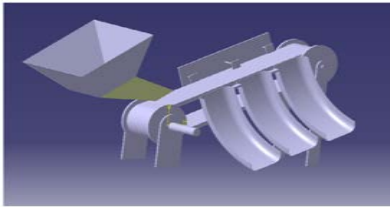

Figure 2: concept1 Trapezoidal Hopper Conveyor Mechanism

Procedure:-Feed from hopper falls directly on the conveyor. The image processing module will be over the conveyor It will stop the rhizomes of suitable sizes and let them fall into the respective guiderails.

Advantages: This sorting mechanism was fast as compared to other mechanisms Suitable when the quantity to be sorted is large.

Disadvantages: Flow from the hopper was not constant. Flow was difficult to control as this was based on the gravity fall mechanism. Often two rhizomes may choke the outlet of the hopper. Providing vibrations was challenging considering the space constrains. Often 3-4 rhizomes may fall on the conveyor making it useless for image processing.

Cost of the manufacturing was high, Cost of bought out parts was even higher.

4.2 Conical Hopper with Rotating Wheel

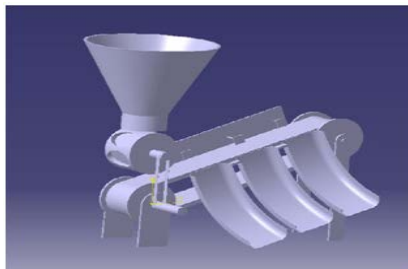

Figure 3:- Concept No 2- Conical Hopper with rotating wheel

Procedure: The feed is given to the hopper; the hopper transfers the feed in single units on the rotating wheel below it. The wheel gives a single rhizome on the conveyor, the rhizome is image processed on the conveyor, and the rhizomes are put into the three guiderails based on their sizes.

Advantages: Even faster than the previous model, Suitable when the quantity of the turmeric to be separated is high, the round hopper ensures that all the pieces create a vortex flow in hopper thereby increasing its efficiency. The Wheel ensures that there are no heaps of turmeric formed on the conveyor.

Disadvantages: The structure of the design is complex yet delicate and it is prone to damage. The consumption of electricity in this particular design is very high as compared to the other alternatives. The manufacturing cost of the Hopper, Conveyor, and Wheel is very high as compared with other simple structured models. It consumes a larger

carpet area as compared to the other models Therefore, taking into account all the disadvantages the aforementioned design was rejected .By using this design as the starting concept, another design was developed which answered some of the problems of this design.

4.3 Scotch Yoke Mechanism Operated Actuator

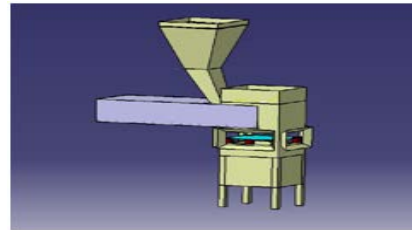

Figure 4:- Concept No-3 Scotch yoke mechanism operated actuator

Procedure: The feed is given into the hopper. The feed is later transferred on the conveyor in the box. A scotch yoke mechanism is used to spate out one rhizome out of the heap. Hence the Rhizome goes to camera module where it is analyzed. The analyzed rhizome is later sorted by the sorting mechanism using tilt plate.

Advantages: Accurate in sorting the rhizomes. Slower but efficient rate of sorting. The machine consumes less space. Can be moved from place to place.

Disadvantages: Not suitable when the feed is in larger quantity. Very critical to operate mechanically as all the parts are enclosed. The rhizomes may get broken due to lack of space. The manufacturing processes required are very expensive. Efficiency is lesser as compared to other designs.

Therefore, taking into account all the disadvantages the aforementioned design was rejected .By using this design as the starting concept, another design was developed which answered some of the problems of this design.

4.4 Gravity Feed Mechanism

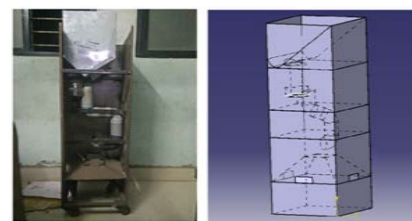

Figure 5:- Concept No.4 Gravity Feed Mechanism

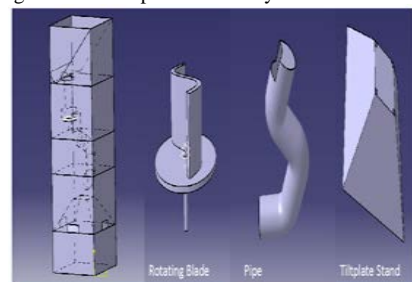

Figure 6:- Parts of Concept No-4

Procedure: The feed is given into the hopper. The feed is later transferred on the container. A rotating blade flicks the rhizomes in out of the container. A rhizome through a pipe goes to required image processing. Hence the Rhizome goes to camera module where it is analyzed. The analyzed rhizome is later sorted by the sorting mechanism using tilt plate.

Advantages: Occupies lesser surface area. Compact in size as compared to other mechanisms. Flow is by virtue of potential energy. No breakage of rhizome. Suitable for continuous flow through hopper. Provides Enclosure to the hopper thereby making it durable

Disadvantages: Mfg. cost is high due to vibration providing mechanism. Difficult to control the flow of rhizomes. Lesser space available for mounting the camera module. Camera doesn't get proper view for image rhizomes. Sorting mechanism selected was not giving satisfactory results. A bit difficult to repair in case of breakdown due to enclosure.

Therefore, taking into account all the disadvantages the aforementioned design was rejected .By using this design as the starting concept, another design was developed which answered some of the problems of this design.

4.5 Pneumatic Cylinder Mechanism

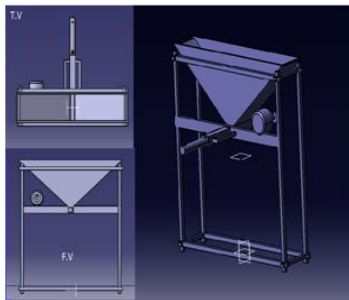

Figure 7:- Concept No 5 -Pneumatic Cylinder Mechanism

Procedure: The feed is given into the hopper . A pneumatic cylinder stroke is used to spate out one rhizome out of the heap. Hence the Rhizome goes to camera module where it is analyzed. The analyzed rhizome is later sorted by the sorting mechanism using tilt plate.

Advantages: - Portable to move. Effective when the quantity to be sorted is high. The image processing module can cover a larger area. Image processing module gets accurate results as the tilt plate is illuminated properly due to ambient light. Shape of hopper ensures that the rhizome moves in a single direction without changing its orientation. The mechanical and electronic modules are separated and hence easy to operate or repair. The vibrations provided by the motor with an eccentric weight which reduces the cost considerably. Height of the module is reduced due to the velocity of falling rhizomes.

Disadvantages: Consumes more electric power. Chances of breakage of rhizomes. The camera is not covered hence can get damaged. The mechanical system is depending on the electronic system and hence when the electronic system fails the mechanical system also fails. The mountings are open and protruding. Higher chances of breakage if not kept in proper place. The required result not done properly. The tilting mechanism not obtains properly the solenoid valve cannot lift the plate properly. The maintenance cost is more if any part breaks down. The compressor attachment required more space and in the field work the machine cannot work without compressor.

Therefore, taking into the disadvantages the aforementioned design was rejected .By using this design as the starting concept, another design was developed which answered some of the problems of this design.

4.6 Design of Anti gravity mechanism

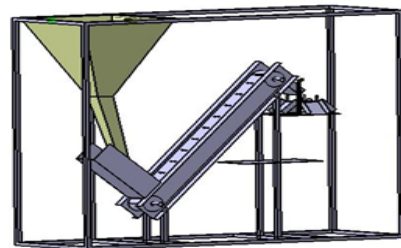

Figure 8:-Concept No 6- Anti Gravity Mechanism

Procedure: The feed is given into the hopper. The feed is later transferred on the conveyor The conveyor conveys the rhizomes a flat plate placed in upper side of a conveyor and put the rhizome. Hence the Rhizome goes to camera module where it is analyzed. The analyzed rhizome is later sorted by the sorting mechanism using tilt plate. The rhizomes get sorted in required section of a size.

Advantages: Accurate in sorting the rhizomes. Efficient rate of sorting. The machine easy to convey. It can be moved from place to place. The rhizomes may not break. Efficiency is more as compared to other designs. Easy to maintenance in mechanical part. Easy to operate.

A. Comparison of Concepts

The process of a concept selection is done by screening method. The concept no 6 is selected to built a prototype.

B. Design calculations

Design of Belt Drive

Power =36watt. Centre distance =1000mm, Thickness of belt =3mm, Density of belt material= 100 g/cc. V=0.052m/s, F=1.5 (assume)

Diameter of a pulley

$$V = \frac{\pi d n}{60 \times 1000}$$

$$d = \frac{60 \times 1000 \times 0.052}{\pi \times 10} \quad d = 99.31 \text{mm}$$

$$d = 100 \text{mm}$$

D1 and D2 both are similar pulleys hence,
D1=100mm, D2=100mm

Length of belt

$$L = 2c + \frac{\pi(D+d)}{2} + \frac{(D-d)^2}{4c}$$

$$L = 2031.41 \text{ mm}$$

Therefore length of belt is 2032mm

Belt tension

$$as = 180 - 2\sin^{-1}\left(\frac{D-d}{2c}\right),$$

$$as = 180 - 2\sin^{-1}\left(\frac{100-100}{2 \times 1000}\right),$$

$$as = 180 = 3.14 \text{ rad}$$

Assume $\mu = 0.3$ We know,

$$\frac{T1}{T2} = e^{\mu\theta}$$

$$\frac{T1}{T2} = e^{0.3 \times 3.142}$$

$$T1 = 2.565T2$$

We have, $P = (T1 - T2)v$,

$$36 = (2.565T2 - T2)$$

$$T2 = \frac{36}{(1.565) \times (0.052)}$$

$$T2 = 442.36 \text{ N}$$

$$T1 = 1134.65 \text{ N}$$

Design of shaft

Select material of shaft - Mild Steel.

$$S_{YT} = 250 \text{ N/mm}^2$$

$$S_{SY} = \frac{S_{YT}}{2} = 125 \text{ N/mm}^2, \text{ Considering factor of safety}$$

(FOS) = 1, Diameter of pulley = 100mm, Length of shaft = 240mm, $W_p = 14.71 \text{ N}$ (weight of pulley), Length of shaft = 240mm, $T1 = 1134.65 \text{ N}$, $T2 = 442.36 \text{ N}$

Ratio of $T1$ & $T2 = 2.565$, $P = 36 \text{ watt}$

Torque transmitted

We have a formula

$$P = \frac{2\pi n T}{60}$$

$$T = \frac{60 \times P}{2\pi n}$$

$$T = \frac{60 \times 36}{2\pi \times 10}$$

$$T = 34.377 \text{ N.m}$$

Total weight act on a pulley

$$W = W_p + T1 + T2,$$

$$W = 14.71 + 1134.65 + 442.56$$

$$W = 1591.92 \text{ N}$$

Reaction at support

$$R_A = R_B = \frac{W}{2} = \frac{1591.92}{2} = 795.96 \text{ N}$$

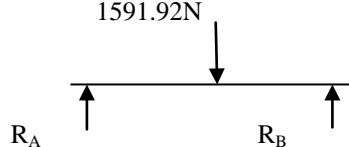

The maximum bending moment at center

$$M = \frac{wL}{4}$$

$$M = R_A \times L = 795.96 \times 240 = 191.0304 \times 10^3 \text{ N.m}$$

Equivalent torque

$$T_e = (M^2 + T^2)^2$$

$$T_e = (191.0304 \times 10^3)^2 + (34.377 \times 10^3)^2$$

$$T_e = 34.379 \times 10^3 \text{ N.m}$$

Stress induced in shaft

$$T_e = \frac{\pi}{16} \times as \times d^3$$

$$d^3 = \frac{34.379 \times 10^3 \times 16}{\pi \times 84}$$

$$d^3 = 2084.41$$

$$d = 12 \text{ mm}$$

It is new development when at the requirement of machine changes suddenly that, is creating problem hence we choose the diameter of shaft is 25mm of mild steel material.

$$d = 25 \text{ mm}$$

Bearing selection

The selection of the type of bearing in a particular application depends upon the requirement of the application. Here Deep groove ball bearing, are suitable in application where radial load acting on the bearing consist of the component

F_r - Radial force acting on bearing

F_a - Axial force acting on bearing

N - rpm of shaft

L_{10h} - Bearing life in hrs. for 90% reliability

P - Equivalent dynamic load, C - Dynamic load capacity,

C_o - Static load capacity X & Y - Factors for radial and axial load from

$$F_r = 1591.92 \text{ N}$$

$$N = 10 \text{ rpm}$$

$$L_{10h} = 20,000 \text{ hrs Consideration}$$

[From SKF official site]

For 25 mm diameter of shaft

Bearing is subjected to a pure radial load

$$F_r = P = 1591.92 \text{ N}$$

$$d = 25 \text{ mm}$$

$$P = 1591.92 \text{ N}$$

$$L_{10} = \frac{60 * N * L_{10h}}{10^6}$$

$$L_{10} = \frac{60 * 10 * 10,000}{10^6}$$

$$L_{10} = 6 \text{ million of revolution}$$

$$C = P(L_{10})^{1/3}$$

$$C = 1591.92(6)^{1/3}$$

$$C = 2892.7106 \text{ N}$$

Therefore used the following suitable bearing

Bearing No= 61804, Bearing No= 16404, Bearing No= 6004, Bearing No= 6005, Bearing No= 6205. We select the Bearing 6205 which is easy available in market as the square shape housing

Belt Selection:-

The tension on a belt is less. The conveys the weight of rhizomes is very less, so we choose the PVC material use as belt material

7 Static Structural Analysis of assembly of design

Designed component in the modeling software will be assemble and import in the Analysis software to carry out a

static analysis. To finding the design is safe or not. The Failure Modes and Effects Analysis (FMEA) is a systematic method for which potential failures of a machine or process design are identified, analyzed and documented. Once identified, the effects of these failures on performance and safety are recognized and appropriate actions are taken to eliminate or minimizes the effects of these failures. An FMEA is a crucial reliability tool that helps avoid costs incurred from product failure and liability. In this case we used the all the mild steel material as defining the material properties for generating mesh in this software element is fine meshing is selected for generating good results as shown in Figure 9

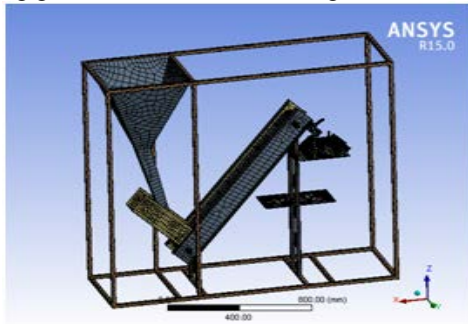

Figure 9:- Meshed Geometry of square tube

For applying boundary Conditions Structural loading means applying. The standard earth gravity applied on the assembly of automatic sorting machine, which is shown by yellow coloured arrows in the Figure. All degrees of freedoms of are restricted and it is shown with the help of blue colour in the Figure10

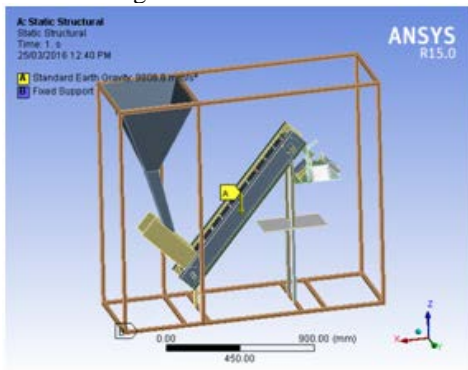

Figure 10:- Apply the boundary condition

Results are obtained in this software after defining Total deformation and Equivalent Stress (von-misses stress) as shown in Figure 11

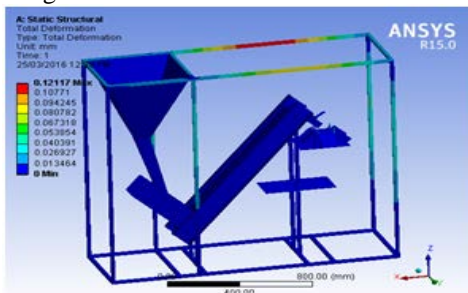

Figure 11:- The total deformation of assembly

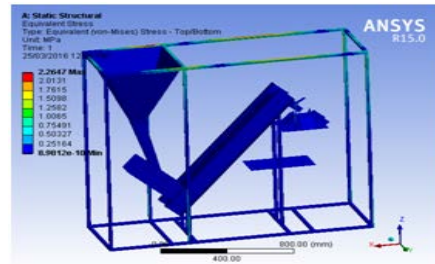

Figure 12:- Equivalent stress in sorting machine

Finally, optimal parameters were chosen for the final design and FEA was regenerated for the sorting machine. The maximum deformation value measured at 0.12117 and The maximum equivalent stress value was measured at 2.2647 MPa. It can be seen that if stress results of the final design was still within the yield stress value of the construction material. Hence, the final design works without any failure In fact, for a total new design process of a Automatic sorting Machine for cooked and dried turmeric rhizomes is safe After all the things done properly we built the Automatic Sorting Machine for Cooked &Dried turmeric rhizomes.

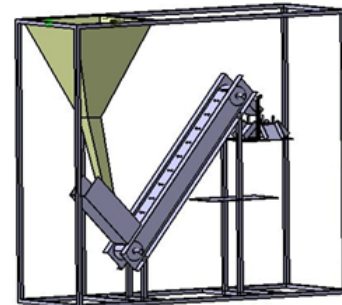

Figure 13:-3D view of Automatic sorting machine for cooked & dried Turmeric Rhizomes

8 Testing and Experimentation

- We performed testing of the machine by using a unit quantity and sorted it in a unit time
- Weight of test quantity: 1kg.
- Number of Turmeric rhizomes in 1 kg: 110 rhizomes (approx).
- Time required for one rhizome to come on tilt plate as per requirement : 1 sec
- Time required for one rhizome to capture the image : 0.9 sec
- Time required for image processing : 0.2 sec
- Total time required for testing 1 rhizome: 1.2 sec.
- Total time required for testing 1 kg of rhizome : 132 sec(approx 2min.)
- A normal working shift runs for 8hrs.: 8 X 60 X 60 : 28800 sec

Therefore the total quantity that can be sorted in one working shift can be found out by dividing the total time in one shift(seconds) by time required to sort 1 kg rhizomes.
 $28800 / 132 = 218.181818\text{kg/per shift}$
 Approximately 218kg rhizomes sorting per day.
 Therefore the total number of rhizomes that can be sorted out in one shift
 $= 218.18 \times 110$
 $= 23999.99$

=24000 rhizomes per shift sorted.

If 3 shifts of 8hrs each are run then the total quantity of rhizomes that can be sorted in 24hrs is conducted
 $24 \times 60 \times 60 = 86400 \text{ sec.}$

Quantity of rhizomes that can be sorted in 24 hrs is:=
 $86400 / 132$

654.54545kg

Number of rhizomes per 24 hrs = $655 \times 110 = 72000$
 rhizomes per 24 hrs.

9 Experimental result & Discussion

If we consider testing for 10 rhizomes

- 7 rhizomes at rate of 1 /sec
- 2 slots remain empty
- 1 slot carries more than 1 rhizome at the same time.

Efficiency of sorting : $(7 / 11) \times 100 = 70\%$

Probability of getting empty slots = 20%

Probability of getting more than 1 = 10%

Therefore 10% of total quantity will be re –processed

That is 30 % of the total 24 hrs shift will be wasted.

$(30 / 100) \times 654 = 196 \text{ kg}$

Therefore 196kg of rhizomes need to be re sorted

$654 - 196 = 458 \text{ kg}$ of rhizomes will be sorted per day.

After considering a slack time of 3hrs :

30 % of the total 21 hrs shift will be wasted .

$(30 / 100) \times 573 = 171 \text{ kg}$

Therefore 171 kg of rhizomes need to be re sorted

$573 - 171 = 402 \text{ kg}$ of rhizomes will be sorted per day

That gives $402 \times 7 = 2814 \text{ kg}$ sorted rhizomes per week

TABLE 1 RESULT TABLE

Number of rhizomes per shift	24000
Quantity of Rhizomes per shift	218 kg
Number of rhizomes per 24hrs	86400
Quantity of rhizomes per 24 hrs	655 kg
Efficiency of sorting for 24 hrs	70%
Quantity of rhizomes that need to be sorted again	30%

5. CONCLUSION

Automatic sorting method after fabrication is tested on site. Results obtained were fulfilling the objectives justified. The machine is portable, durable and can perform under any diverse conditions. Requirement of electricity is necessary. Power supply provided is very compact and machine maintenance is very low.

Its operation is easy and does not require any skilled labor after installations. There is no chance of any hazard from the machine. The machine can be commercialized for any capacity by just scaling up the same design. The machine can also be installed on a trolley for transportation to different sites. There is no possibility of damage due to vibrations to the machine. The frame on which sorting machine is mounted is very rigid and can withstand machine weight. Radial forces acting on a conveyor assembly are negligible and therefore life of various mountings such as ball bearings, pulleys, idlers etc. is very long. This makes machine more durable.

The automatic turmeric rhizomes sorting machine has been developed which is able to sort turmeric rhizomes as per size. We observed that the efficiency of a sorting is up to 70%.

6. FUTURE SCOPE:

- The machine can be commercialized by setting up turmeric processing plant for sorting.
- Automation can be further provided in the form of feed to the hopper from hips of rhizomes by mechanical modifications (Feeder)
- Pneumatic Cylinder is a promising concept which can even provide more efficient sorting if the little consequences are eliminated.
- Polishing of Turmeric rhizomes can be integrated in this machine by supplementing it with polishing equipment.

REFERENCES

- [1] M.Khojastehnazhand, M. Omid and A. Tabatabaeefar Department of Agricultural Machinery Engineering, "Development of a lemon sorting system based on color and size" African Journal of Plant Science Vol. 4(4), pp. 122-127, April 2010.
- [2] S.J. Ojolo, J.I. Orisaleye, Adelaja, A.O., Kilanko, O Mechanical Engineering Department, University of Lagos, "Design and Development of Waste Sorting Machine" Journal of Emerging Trends in Engineering and Applied Sciences (JETEAS) 2 (4): 576-580 2011 (ISSN: 2141-7016)
- [3] Tom Pearson • Dan Moore • Jim Pearson "A machine vision system for high speed sorting of small spots on grains" _ Springer Science Business Media New York (Outside the USA) 2012 30 September 2011 / Accepted: 11 October 2012 / Published online: 27 October 2012
- [4] Yud-RenChen ,Kuanglin Chao, Moon S. Kim "Machine vision technology for agricultural applications". Elsevier Computers and Electronics in Agriculture(36 2002) 173_/191
- [5] Pla, F., Sanchiz, J.M., Sánchez, J.S. "An integral automation of industrial fruit and vegetable sorting by machine VISION" Enginyeria Visual. UniversitatJaume I, Campus Riu Sec, 12071 Castelló (SPAIN).
- [6] S Balasubramanian*, A M Mohite, K K Singh1, T John Zachariah2 & T Anand "Physical properties of turmeric (Curcuma longa L.)" Central Institute of Post Harvest Engineering and Technology, Ludhiana-141 004, Punjab, India. Journal of Spices and Aromatic Crops Vol. 21 (2) : 178-181 (2012)
- [7] Book Karl T Ulrich (2009) Product Design and Development. 4th Edition, Tata McGraw Hill Publication. New Delhi.