

FIELD CONTROLLED DC DRIVE USING MOSFET BASED CHOPPER CONTROL

R.Venkatesh¹

¹(EEE Department, SNS College of Engineering, Coimbatore, India, rvenkatesh48@gmail.com)

Abstract—DC Motor plays a vital role as drives in the Automation industries. The speed of the drives needs to be controlled according to its applications. Generally the speed control of DC motors is carried out in two ways namely Armature control and Field control methods. Armature control method is adopted while the speed of the drive is below rated speed and field control method for the above rated speed. The project is carried out to design and analyze the soft switching variable speed drive for 18W DC Shunt motor. Type of speed control used in proposed system is field current control and the type of speed drive is MOSFET based chopper. The duty cycle of the chopper drive is varied by PIC Microcontroller. Soft switching variable speed drive paves the way for modernization of speed control of DC motor. The proposed method of soft switch drive will provide fine variations of speed.

Keywords—Chopper; PWM technique

1. INTRODUCTION

DC Motor plays a vital role as drives in the Automation industries. The speed of the drives needs to be controlled according to its applications. Generally the speed control of DC motors is carried out in two ways namely Armature control and Field control methods. Armature control method is adopted while the speed of the drive is below rated speed and field control method for the above rated speed. The major drawback of the conventional speed control method is more power loss. Hence the efficiency of the drive will be reduced. In this article, it is carried out to design and analyze the soft switching variable speed drive for 18W DC Shunt motor. Separate starter is not used in the proposed system. Type of speed control used in proposed system is field current control and the type of speed drive is MOSFET based chopper. The duty cycle of the chopper drive is varied by PIC Microcontroller. Soft switching variable speed drive paves the way for modernization of speed control of DC motor. The proposed method of soft switch drive will provide fine variations of speed.

2. PROPOSED SYSTEM

18W DC motors circuitry is designed, and developed using pulse with modulation (PWM). The pulse width modulation can be achieved in several ways. In this project, the PWM generation is done using PIC microcontroller. The output of the chopper is given to the 18W DC motor. Chopper input is given from the supply. PIC microcontroller generates the PWM pulses and these pulses are given to the chopper drive as duty cycles. PIC microcontroller acts as gate control circuit for chopper drive. The project proposed is a real time working project, and this can be further improvised by using the other safety features. In the existing system rheostat method is used to perform the speed control of DC motor. As the entire field current passes through the external resistance, a tremendous amount of heat can be generated. Rheostat required is of large size and capacity. The method needs expensive heat dissipation arrangements. In this method minute variations of speed cannot be achieved. To

modernize the electrical machines laboratory by controlling the DC motor through Chopper drive. To design MOSFET based chopper to control DC motor speed. To develop controller for chopper using microcontroller.

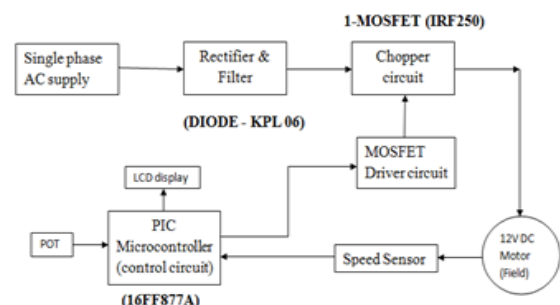

Fig. 1: Block diagram of proposed soft switching speed drive.

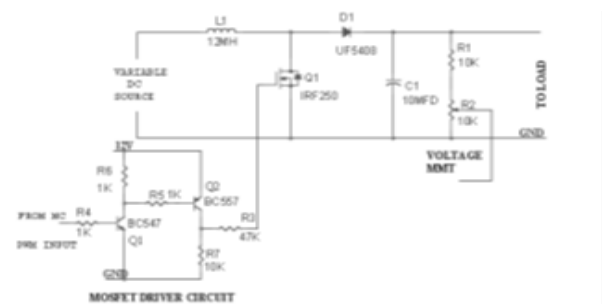

Fig. 2: Circuit diagram of proposed soft switching variable speed drive.

3. OPERATION OF THE CIRCUIT

A chopper is a "on" or "off" semiconductor switch which is so high in speed. It connects source to load and disconnect the load from source at a fast speed. As shown in Fig1. During the period T_{on} , chopper is on and load voltage is equal to source voltage V_s . During the period T_{off} , load voltage is zero and chopper is off. In this manner, a chopped dc voltage is produced at the load terminals. A boost converter is also called a step-up converter. Its principle of operation is illustrated by referring to Fig. This converter is used to produce higher

voltage at the load than the supply voltage. When high pulse signal is given to base of the Q1 transistor, the transistor is conducting and shorts the collector and emitter terminal and zero signal is given to base of the Q2 transistor. So high pulse is goes to the base of the MOSFET Q3 then it will ON automatically. If the input of the transistor Q1 is low then the input of the MOSFET Q3 is also low so MOSFET is turn OFF. This is the driver circuit for chopper.

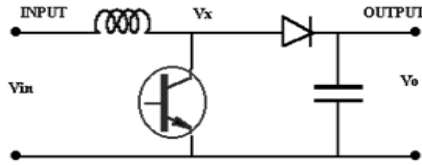

Fig. 3: Circuit diagram of boost converter.

Average Voltage, $V_o = (T_{on} / (T_{on} + T_{off})) * V_s$
 $V_o = (T_{on} / T) * V_s$
 $V_o = \zeta * V_s$

Design Calculation

The supply voltage to the chopper, $V_s = 12\text{ V}$
 The average output voltage of the chopper is
 $V_o = \zeta * V_s$
 $V_o = 6\text{ V}$
 $6 = \zeta * 12$
 $\zeta = 6/12$
 $\zeta = 0.5$

Therefore the duty ratio of the chopper, $\zeta = 0.5$
 The field input voltage of the motor,
 $V_f =$ The output voltage of the chopper, V_o
 $V_f = 6\text{ V}$
 $I_f = V_f / R_f$
 $R_f = 4.3\ \Omega$
 $I_f = 6/4.3$
 $I_f = 1.39\text{ A}$

Table - I. Speed vs Field current

S.No	Supply voltage, V_s (volts)	Duty ratio, ζ	Output voltage of the chopper, V_o (volts)	Field input voltage of the motor, V_f (volts)	Field resistance, R_f (Ω)	Field current, I_f (A)	Speed N (rpm)
1.	12	0	0	0	4.3	0	0
2.	12	0.25	3	3	4.3	0.69	900
3.	12	0.5	6	6	4.3	1.39	795
4.	12	0.75	9	9	4.3	2.09	430
5.	12	1	12	12	4.3	2.79	309

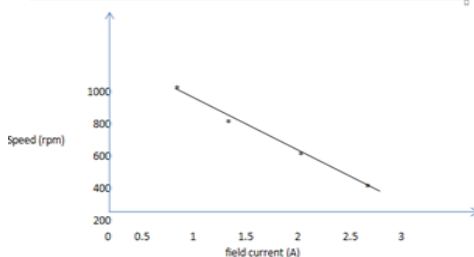

Fig. 4: Speed Characteristics curve of DC motor.

4. CONCLUSION

The variations in the speed (speed control) of 18W, 12V, 1.5A, 1000rpm DC shunt motor is achieved by using the field control method. The field control method is carried out by implementing soft switching technique using MOSFET based chopper in which the duty ratio of the chopper is varied to achieve speed control. The duty ratio of the chopper is varied by using PIC microcontroller. The duty ratio of the chopper ranges from 0 to 1. The Speed variation ranges from 900 to 300 rpm. The minute variations of the speed are achieved.

5. REFERENCES

- [1] Ms.S.R.Bhagwatkar 1, Mr.A.P. Dhande2, Student, Dept. of Electronics and Telecommunication, P.R.Patil college of Engg. and Technology, Amravati, India 1, Professor, Dept. of Electronics and Telecommunication, P.R.Patil college of Engg. and Technology, Amravati,India2, A Review on Automatic Closed Loop Speed Control of a DC Motor, International Journal of Advanced Research in Computer and Communication Engineering, Vol. 4, Issue 1, January 2015.
- [2] Mohd Amir Fikri Bin Awang, A Thesis Submitted in Fulfilment for the Requirement Award of the degree of, Bachelor of Electrical Engineering (Power Systems) Faculty of Electrical and Electronics Engineering University, DC Motor Speed Controller, Malaysia Pahang November, 2010.
- [3] Nurul Izzati Binti Pandak Jabo, Speed Control of DC Motor Using PID Controller Implementation with visual Basic, This thesis is submitted as partial fulfilment of the requirements for the award of the Bachelor of Electrical Engineering (Hons.) (Electronics) Faculty of Electrical & Electronics Engineering University Malaysia Pahang November, 2008.
- [4] Praveen Kumar Nambisan.T.M1, Dr.B.N.Sarkar2, PG Student [Power Electronics], Dept. of EEE, Dayananda Sagar College of Engineering, Bangalore, Karnataka, India1, Professor, Dept. of EEE, Dayananda Sagar College of Engineering, Bangalore, Karnataka, India2, Study of Speed Control of DC Series Motor Using DC Chopper International Journal of Advanced Research in Electrical Electronics and Instrumentation Engineering, vol. 3, issue 8, august 2014.
- [5] K.A.Wadile1, S.R.Chillarge2, D.D.Jadhav3, Pravara Rural Engineering College Loni, Ahmednagar (M.S.), India, Speed Control and Direction Control of Dc Motor Using Arm7 International Journal of Engineering and Computer Science, Volume 4 Issue 2 February 2015.