

A REVIEW ON UNDERWATER WELDING TECHNIQUES, ELECTRODES, EQUIPMENTS USED AND THEIR REQUIREMENTS

Er. Surinder Kumar¹ | Er. Deepak sharma² | Er. Hardeep Kumar³

¹(Research Scholar, Dept. of Mechanical Engineering, LRIET, Solan H.P., H.P. Technical University)

²(Asth. Prof., Dept. of Mechanical Engineering, KCEIT, Una, Himachal Technical University)

³ Asth. Prof., Dept. of Mechanical Engineering, KCEIT, Una, Himachal Technical University

(1992surinder@gmail.com)¹(er.shdeepak@gmail.com)²(hardeep.saini415@gmail.com)³

Abstract— Underwater welding is became most advance and modern technique of welding in the recent years. It is rapidly used in various countries such as India, USA and UAE etc because these countries are organizing the biggest infrastructures in now days. This process is being used as a production tool also. This review presents techniques of underwater welding to assist the development in the field metals and their joining to each other. There are various techniques and method are available of UWW (underwater welding). The selection of heat source, available electrodes, equipments and their requirements, applications and other problems associated with underwater welding have been discussed in this paper. The advantages and future work which can be carried out in this technique is also described in this paper, so this technique can be more accurate and powerful in the area of metal construction and other working areas of welding.

Keywords—UWW, MMRW, TIG, MIG

1) Introduction

Underwater welding is invented by, Van Willigen in 1946, with a substantial amount of iron powder in its flux coating. Further Salinity makes the water to act as an electrolyte and increase the arc stability. Underwater welding can be done in the same manner as arc welding done in air except that there is a rapid cooling action of water, and high pressure due to water head under which welding takes place. Combustion of electrode flux coating materials and dissociation of water from a gas bubble around the arc that contains up to 93% of H₂.As welding continues, the bubbles travels towards the water surface and thus, makes the arc unstable. Gas movement within the envelope and its walls is extremely complex due to continuous rotating convection streams, thus creates turbulence. This complex envelope produces dynamic pressure gradient around the arc column. This welding commonly uses special waterproofed electrodes. Electrical conductivity of bottom sea water is approximately 0.03 U/cm³.

Figure No.1.1: Underwater welding setup

2. CLASSIFICATION of UNDERWATER WELDING

Underwater welding can be divided mainly in two types with sub classification as follows:

1) WET UNDERWATER WELDING It is considered as the welding at the ambient pressure where there is no mechanical barrier between welder and surrounding water. MIG, TIG and PLASMA arc welding is more promising because of arc stability and high heat content in the arc.

2) DRY UNDERWATER WELDING It is considered as welding in dry ambient atmosphere or hyperbaric pressure where welder diver is separated from the surrounding water by means of mechanical barrier which could be divided or designed as several alternatives as follows:-

➤ DRY WELDING AT ONE ATMOSPHERE

Welding can be done in pressure vessel in which pressure is reduced to one atmosphere which is independent of water depth.

➤ DRY WELDING IN A HABITAT

Welding can be done at ambient pressure in a large chamber from which water was displaced and where such atmosphere is achieved that welder has no need to use diving equipment.

➤ DRY SPOT WELDING

Welding at ambient pressure in a small transparent, gas willed enclosure with the welder outside in the water. It uses TIG and MIG welding. TIG is preferred as it gives stable arc and less porous welds. Literature Review

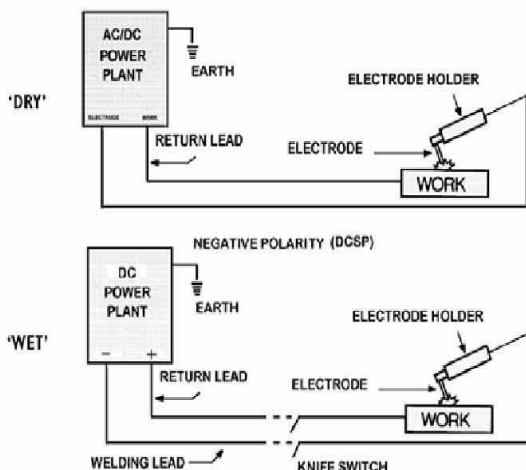

3. PRINCIPLE OF OPERATION IN UNDERWATER WELDING

Electrolysis occurs and cause rapid deterioration of metallic component, when DC is used with positive polarity. On account of electrical safety and difficult to maintain an underwater arc, AC is not used in wet welding. The work to be welded is connected to one side of an electrical circuit, and metallic electrode to other side. These two parts are brought together and then slightly separated. The current produced jumps the gap and creates sustained spark (arc), which melts the bare metal, and forms a weld pool.

Simultaneously the tip of electrode melts, and metallic droplets are projected into weld pool. During this operation, the flux covering the electrode melts, and metal droplets are projected into weld pool. During this operation, the flux covering the electrode melts to form a shielding gas around the arc, which is used to stabilize the arc column and shield the transfer metal. The arc burns in a cavity inside the flux covering, which is designed to burn slower than the metal parallel of the electrode.

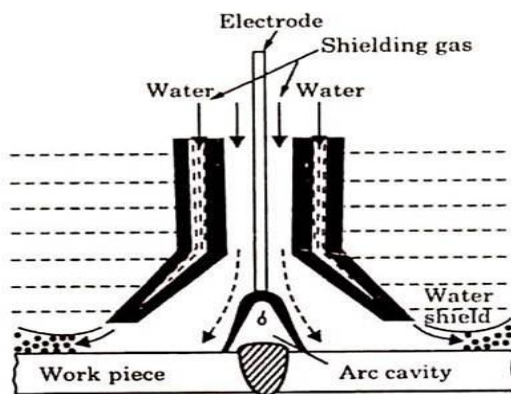

Fig: Underwater Welding Operation

4. ARC CHARACTERISTICS

A welding arc is sustained electrical discharge through a high temperature conducting plasma, producing sufficient thermal energy so as to be useful for joining of metal by fusion. Underwater welding characteristics are always rising i.e., at higher currents, the slope of the curve becomes more steep and also the slope becomes steeper as the arc length increases. With the increase in current and arc length, the electric field strength increases, and when electric current decreases with water depth, arc column diameter increases slightly. Due to H₂ concentration around the arc and the quenching effect of water, higher arc voltages and currents are needed in underwater welding.

For obtaining lower argon arc temperature, arc voltages in argon should be lower and current density is 3-4 times less than for arc. As water depth increases, arc constriction effect is observed and more currents are needed but the potential density does not vary substantially.

➤ ARC STABILITY

During underwater welding the arc-voltage and current values are undulate. A stability factor for comparing arc performance was defined by Madatov as maximum current divided by minimum current (I_{max}/I_{min}) and the arc is considered to be stable near this factor value. One of the causes of these fluctuations is change in arc voltage due to

change in arc length during transfer of metal. Another cause of fluctuation is collapsing of thick flux occurs every 0-3 seconds or less during welding.

➤ ARC ATMOSPHERE

An eccentric feature of underwater welding is formation of arc bubble that continuously maintained around the arc. The size of the arc bubble covers the arc column in between a small bubble and a large bubble of diameter 10-15 mm. that eventually breaks away from weld puddle and floats towards the surface, leaving behind the nucleus bubble of diameter 6-9 mm. This phenomenon of bubble growth and its breaks away occurs at an approximate rate of 15 times per second at 150 mm of water depth. The gas bubble consist of 62-82% of H₂, 11-24% of CO, 4-6% of CO₂ and the remaining 3% of N₂ and metallic and mineral salt vapors.

➤ METAL TRANSFER

In underwater welding, metal transfer takes place in small globules and eventually a large drop form and short circuits the arc. Brown reported drop transfer frequency be 800-1000 drops per second for coated electrodes. Madatov reports the frequency to be 44 drops per second for the type of electrode to be used. Thus the drop transfer frequency depends upon the types of electrodes in addition to other physical and chemical factors related to electrodes. Underwater arc is formed and produces high temperature of core arc about 9000K-11000K at the depth of 10m. This high range of temperature results in fast melting rate of plate and electrode as well. The uncontrollable weld puddle solidifies rapidly due to quenching effect of water.

5. TYPES OF ELECTRODES USED PRESENT WORK

Electrodes used in underwater welding are discussed below:-

1. CELLULOSIC ELECTRODES

These electrodes give a harsh digging arc resulting in high and deep penetration. IN 1933, Hibshman and Jensen investigated these electrodes and found that, during welding, visible clouds of black smoke, tensile strength of weld is slightly higher than air welds but reduced ductility. In underwater welding the currents are usually high and it is difficult to maintain the arc. This has been found to aggravate the situation and produce more undercuts and complex beads. E-6010 has been found to spatter violently, gives irregular bends and produce clouds of black smoke whereas E-6011 gives almost no spatter and produces continuous bead due to presence of potassium silicate in coating.

2. ACID ELECTRODES

Acidic electrodes have high ratio of (silica+titenia) to (iron oxide+manganese oxide). These electrodes have been found to give good result by Berthet. Till now there is no study can be done by anyone except Berthet before arriving at final conclusion.

3. RUTILE ELECTRODES

Rutile electrodes are superior to cellulosic and second to acidic electrodes. Silva and Hazlett have found that plain rutile electrodes inferior to iron powder type. Light coated rutile electrode E-6013 can be recommended by U.S. NAVY in their manual on underwater welding and cutting in 1953. Using Shellac and Paraffin as water proof coating, they can be successfully operated with A.C. temperature and turbidity improves arc stability.

4. OXIDIZING ELECTRODES

Oxidizing electrodes give satisfactory welds but the welds formed are inferior to strength and ductility as compared to acid and rutile electrodes and also have poor tensile strength.

5. IRON-POWDER ELECTRODES

In 1946, Mr. VAN WILLENGEN developed an electrode with a substantial amount of iron powder in its coating and has high coating material to core wire ratio. These electrodes are found easy to use in low visibility conditions and have excellent drags. Madatov in 1962 found these electrodes to give stable arc and fine droplet transfer with occasional short circuits. For E-6013, better electrode coatings have to be designed to remove chipping of external coating during welding. These electrodes have been found useful but because of arc elongation effect, they would not give satisfactory results. Plain rutile coating would not minimize this effect but strength of welds is better than the iron powder electrodes.

6. UNDERWATER WELDING PROCESSES

The fusion welding process of greatest practical significance in underwater welding at present are: MMAW i.e., extensively used as wet technique but it is also suitable for wet welding.

1. TIG welding
2. MIG welding
3. MANUAL METAL ARC WELDING

MMAW is an economical process for underwater welding and this process can be carried out in all positions. The DC welding equipment we use must have a capacity of 300 ampere for each welder. Ferrite electrodes with a coating of iron oxide should be used as they resist H₂ coating. Positive polarity of the workpiece is preferred which means that 65-75% of heat is in the metal being welded. The weld pool formed is easier to handle and has enough fluidity to fill in undercut at large extent. The electrode coating crumbles from electrode tip and the welder maintains the proper arc length so that the arc should be same as that of surface welding. The speed of welding, even in clear water, will be slower than the speed when welding is carried out at surface (in air).

TIG WELDING Tungsten inert gas welding has the advantage to produce stable arc and less porous welds. Yet this process is relatively slow, it is very flexible and can accommodate variations in fit up and produces high quality penetration beads. In TIG welding, as the depth or pressure

increases:- The arc contracts and voltage increases for given arc length. Tungsten tip starts getting eroded and its phenomenon influences weld bead width and penetration. When this process is carried at high pressure, the erosion of tip gives rise to arc instability. Initiation of arc becomes more difficult.

MIG WELDING Due to high cost of diving operations, metal inert gas welding is highly desirable to complete weld in minimum period of time. Thus it gives direct attention to the use of semi- automatic processes. Wire contains various oxidizing and reducing elements that gives good results even without shielding. CO₂ or argon is used as shielding gas. Shielding gas gets denser and has flow rate up to 10 times the surface rates. MIG is faster and less expensive than TIG welding and MIG dry welding is preferred to MIG wet welding for obtain satisfactory welds.

9. SCOPE FOR FURTHER WORK

The field in which immediate work is needed includes:

Comparative study can be done on the effect of water pressure on arc characteristics and weld deposit strength. The effects of working conditions on operator performance can be measured. We can try for development for welding process for larger depths. Versatile welding and cutting equipment used in Underwater Welding. Study of fatigue strength of welds can be calculated for UWW. We can also study the static and dynamic characteristics of welds, heat flow variations in underwater welds and strength analysis on underwater welds in future.

10. References

- [1] M. I. Khan, Shankar Lal "State of art in underwater welding" IE (1) Journal ME vol-56, pt ME 5 May 1976.
- [2] C. E. Jackson. "The Science of Arc Welding-Part 1". Welding Journal, vol-39, no 4, p 129(1960).
- [3] G R Salter. "Gas Metal Reactions in Arc Welding", British Welding Journal, vol-12, no 5, 1965, p 222.
- [4] Madatov, N. M., "Underwater Welding Electrode with Coating Containing Iron Powder", Welding Production, Vol-9, No. 8, pp 25. (1962).
- [5] Silva, E. A. "An Investigation of Fusion Controlled Metallurgical Bonding in the Marine Environment," Ph.D., University of California at Berkeley, (1971).
- [6] Brown, A., Staub, J. A., and Masubuchi, K., "Fundamental Study of Underwater Welding," OTC 1621, pp. 55-64 (1972).
- [7] Van Der Willigen P.C. Contact Arc Welding, Welding Journal, vol. 25, No. 5, pp. 313s-320s(1958).

- [8] Brown, A.J. et al "Fundamental Research on Underwater Welding, "Report No. MITSG 74-29, (September 1974).
- [9] Madatov, N. M., "Influence of the Parameters of the Underwater Welding Process on the Intensity of Metallurgical Reactions," Welding Research Abroad, March, p. 63(1972).
- [10] Waugh, R.C. & Eberlein, O.P., " Underwater Metallic Arc Welding", Welding Journal Research Supplement , Vol. 33, No. 10, pp.531-s to 534-s(1954).